

VIDEOLOGY®

IMAGING SOLUTIONS INC.
Original Equipment Manufacturer

OSD Instructions 24C1.3XW WDR Analog 800TVL



Prior to Using This Document: Videology reserves the right to modify the information in this document as necessary and without notice. It is the user's responsibility to be certain they possess the most recent version of this document by going to www.videologyinc.com, searching for the model number, and comparing revision letters on the respective document, located in the document's footer.

For technical assistance with this product, please contact the supplier from whom the product was purchased.

License Agreement (Software):

This Agreement states the terms and conditions upon which Videology Imaging Solutions, Inc. USA and Videology Imaging Solutions, B.V. Europe (hereafter referred to as "Videology®") offer to license to you the software together with all related documentation and accompanying items including, but not limited to, the executable programs, drivers, libraries, and data files associated with such software.

The Software is licensed, not sold, to you for use only under the terms of this Agreement.

Videology grants to you, the purchaser, the right to use all or a portion of this Software provided that the Software is used only in conjunction with Videology's family of products.

In using the Software you agree not to:

- Decompile, disassemble, reverse engineer, or otherwise attempt to derive the source code for any Product (except to the extent applicable laws specifically prohibit such restriction);
- Remove or obscure any trademark or copyright notices.

Limited Warranty (Hardware and Software):

ANY USE OF THE SOFTWARE OR HARDWARE IS AT YOUR OWN RISK. THE SOFTWARE IS PROVIDED FOR USE ONLY WITH VIDEOLOGY'S HARDWARE. THE SOFTWARE IS PROVIDED FOR USE "AS IS" WITHOUT WARRANTY OF ANY KIND, TO THE MAXIMUM EXTENT PERMITTED BY LAW, VIDEOLOGY DISCLAIMS ALL WARRANTIES OF ANY KIND, EITHER EXPRESS OR IMPLIED, INCLUDING, WITHOUT LIMITATION, IMPLIED WARRANTIES OR CONDITIONS OF MERCHANTABILITY, QUALITY AND FITNESS FOR A PARTICULAR APPLICATION OR PURPOSE. VIDEOLOGY IS NOT OBLIGATED TO PROVIDE ANY UPDATES OR UPGRADES TO THE SOFTWARE OR ANY RELATED HARDWARE.

Limited Liability (Hardware and Software):

In no event shall Videology or its Licensor's be liable for any damages whatsoever (including, without limitation, incidental, direct, indirect, special or consequential damages, damages for loss of business profits, business interruption, loss of business information, or other pecuniary loss) arising out of the use or inability to use this Software or related Hardware, including, but not limited to, any of Videology's family of products.

Table of Contents

1. Document History	1
2. Warning	1
3. Precautions	2
4. Camera Operation	2
4.1 Menu	2
4.2 How to Setup the Functions	2
4.3 Focus Adj	2
4.4 Lens	2
4.5 Exposure	2
4.6 White Balance	3
4.7 Backlight	3
4.8 DNR	3
4.9 Day & Night	4
4.10 Image	4
4.11 Special	4
4.12 System	5
4.13 Exit	5
5. Troubleshooting	5
6. Specifications	6
7. Contact Information	6

1. Document History

Revision	Issue Date	Reason	CN#
Rev A	08-27-14	Initial release	Preliminary



The lightning flash with an arrowhead symbol, within an equilateral triangle is intended to alert the user to the presence of uninsulated dangerous voltage within the product's enclosure that may be of sufficient magnitude to constitute a risk of electric shock to persons.



The exclamation point within an equilateral triangle is intended to alert the user to the presence of important operating and maintenance (servicing) instructions in the literature accompanying the appliance.

INFORMATION - This equipment generates, uses, and can radiate radio frequency energy and, if not installed and used in accordance with the instruction manual, may cause harmful interference to radio communications. As an OEM product, it is expected and recommended that the user will place this model into a proper housing.

Operation of this equipment in a residential area is likely to cause harmful interference in which case the user will be required to correct the interference at his own expense.

WARNING: Changes or modifications not expressly approved by the manufacturer could void the user's authority to operate the equipment.

CAUTION: To prevent electric shock and risk of fire hazards:
- Do NOT use power sources other than those specified.
- Do NOT expose this appliance to rain or moisture.

This installation should be made by a qualified service person and should conform to all local codes.

2. Warning

- The camera requires periodic inspection. Contact an authorized technician to carry out the inspection.
- Stop using your camera when you find it malfunctioning. If the camera emits smoke or is unusually hot for a long period, a fire may be caused.
- Do not install the camera on a surface that cannot support it. If the camera is installed on an inappropriate surface, it may fall and cause injury.
- Do not hold plug with wet hands. It could cause an electric shock.
- Do not dis-assemble the camera. It may result in an electric shock or other hazards.
- Do not use the camera close to a gas or oil leak. It may result in a fire or other hazards.

3. Precautions

- Do not install the camera in extreme temperature conditions. Only use the camera under conditions where temperatures are between -10°C and +50°C.
- Be especially careful to provide ventilation when operating under high temperatures.
- Do not install or use the camera in an environment where the humidity is high. It can cause the image quality to be poor.
- Do not install the camera under unstable lighting conditions. Severe lighting change or flicker can cause the camera to work improperly.
- Do not touch the front lens of the camera. This is one of the most important parts of the camera. Be careful not to leave fingerprints on the lens cover.
- Do not drop the camera, protect it from physical shock. These malfunctions will occur.
- Do not expose the camera to rain or spills. If it gets wet, wipe it dry immediately. Liquids can contain minerals that corrode the electronic components. Never keep the camera pointed directly at strong light. It can damage the sensor.
- Do not expose the camera to radioactivity. If exposed to radioactivity the sensor will fail.

Note:

- If the camera is exposed to a spotlight or an object reflecting strong light, smear or blooming may occur. HLC will mitigate this effect.
- Please check that the power supply satisfies the normal specification before connecting the camera.

4. Camera Operation

4.1 Menu

SETUP menu			
FOCUS ADJ			
LENS	ALC	ELC	
EXPOSURE	BRIGHTNESS	SHUTTER	SENS-UP
	AGC	RETURN	
WHITE BAL	AUTO	AUTOext	PRESET
	MANUAL		
BACKLIGHT	OFF	HLC	BLC
	WDR		
DNR	HIGH	MIDDLE	LOW
	OFF		
DAY & NIGHT	MODE	ANTI-SAT	EXTERN S/W
	AGC THRES	AGC MARGIN	DELAY
	RETURN		
IMAGE	SHARPNESS	GAMMA	PEDESTAL
	COLOR GAIN	MIRROR	FLIP
	RETURN		
SPECIAL	CAM TITLE	D-ZOOM	DWDR
	DEFOG	SHADING	INTELLIGENT
	ALARM	QUICK ZOOM	PRIVACY
	COMM ADJ.	RETURN	
SYSTEM	VIEW ANGLE	CVBS	LANGUAGE
	RESET	RETURN	
EXIT			

4.2 How to Setup the Functions

Settings can be adjusted using the built-in joystick, button pad.

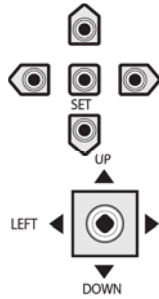

Button pad use: Press the SET button to activate the OSD menu.

Joystick use: Press directly down on the joystick to activate the OSD menu.

- Press the SET button. Settings can now be made. The SETUP menu is displayed on the monitor.
- Select a menu item from the list available by using the UP and DOWN buttons.

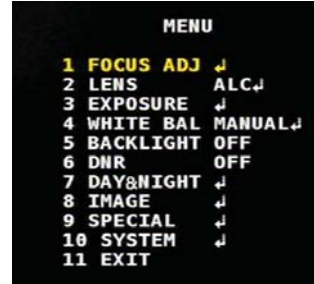

- Functions are selected using up and down buttons.
- The selected position is displayed in Yellow.

Select the desired menu item by using the UP and DOWN buttons

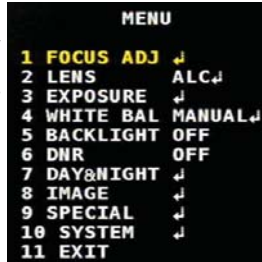

Modes can be changed using the LEFT and RIGHT buttons

- Press the LEFT or RIGHT button to change modes. When the LEFT or RIGHT button is pressed, available values and modes are displayed in order. Keep pressing the button until you get to the mode you wish to select.
- Select 'EXIT' and then press the SET button to exit the set up menu.

Note:

If ↓ appears at the mode selected, it means that there is a sub-menu which can be selected by pressing the SET button.

4.3 Focus Adj

This function is to adjust the focus of Lens.



4.4 Lens

Here you can configure the lens setting.



ALC / ELC:

- If you are using a lens with manual Iris, set this item to ELC.
- If you are using a Iris controlled lens, set it to ALC.

If you choose ALC, you will be able to select if the camera is used indoors or outdoors. The lens and shutter control will be automatically optimized according the present situation.



MODE [INDOOR / OUTDOOR / DEBLUR]: If you choose INDOOR, the Iris and the shutter are set to fixed values. This will prevent a "rolling effect" of the image. If you choose OUTDOOR, the Iris and shutter settings are flexible and will adjust accordingly to the current brightness situation. If you choose DEBLUR, the shutter is set to fixed values to remove an appearance of blur.

4.5 Exposure

The exposure is the amount of light received by the image sensor and is determined by the width of lens diaphragm opening, the amount of exposure by the sensor (shutter speed) and other exposure parameters.

With this item, users can define how the Auto Exposure function.



Scroll to choose from the sub menu items listed below.

Scroll to choose from the sub menu items listed below.



BRIGHTNESS [0 ~20]: This function is used to adjust the brightness of the camera picture.

SHUTTER [1/30, 1/50, 1/60, 1/120, 1/240, 1/500, 1/1000, 1/2000, 1/4000, 1/8000, 1/16000, 1/30000, 1/60000]: You can select one of 14 options from 1/25 to 1/60000K for the fixed high speed electronic shutter, which is mostly used for imaging a fast moving object.



SENS-UP [OFF, AUTO, x2~x60]: Automatically detects the ambient level of darkness in a dark or low contrast scene to extend the accumulated time, keeping the image bright and sharp.

AGC (Automatic Gain Control) [0-20]: The AGC (Auto Gain Control) function is used to amplify the video signal when it falls below the set parameter. As the AGC level increases, the overall screen gets brighter but the level of noise will also increase at the same time.

4.6 White Balance

This function allows the ability to adjust color temperature.



The camera needs to find a reference color temperature, which is a way of measuring the color of a light source, for calculating all the other colors. The unit for measuring this ratio is in degree Kelvin(K). You can select one of the White Balance Control modes according to the installation condition.

AUTO: In this mode, white balance works within its color temperature range. This mode computes the white balance value output using the color information from the entire screen. It outputs the proper value using the color temperature radiating from a black subject.

AUTOext: With the Auto Tracking White Balance function, the white balance in a scene will be automatically adjusted while temperature color is changing. The AUTOext Mode is suitable for environments

with a light source having a color temperature in the range roughly from 1,800 ~ 10,500K (sodium lights to outdoor cloudy environment).

PRESET: This mode is set to the current white balance condition and keeps its value. Select this mode and then press the SET key. If there is a change in location or light source, please repeat this procedure.

MANUAL: Can be used for fine adjustment. Set the White Balance by first using AUTO or AUTOext and then change to MANUAL and press the SET key. Increase or decrease the value of R-Gain (Red) and B-Gain (Blue) while monitoring the color of the image.

- **KELVIN** [MIDDLE / HIGH / LOW]:
- **R-GAIN** : Adjusts the White Balance for the color Red.
- **B-GAIN** : Adjusts the White Balance for the color Blue.



4.7 Backlight

When there is a strong backlight behind the object, clear images of the background as well as the object can still be obtained by using the BACKLIGHT function.



OFF: Not being used.

HLC (High Light Compensation): This function is used to suppress or mask a strong light source (for example, headlights of cars during nighttime) so that other subjects can be seen in more detail. If you select HLC, a submenu appears where you can make finer adjustments.



- **HLC LEVEL**: Adjust the brightness level from which on the light source is to be masked out.
- **MODE**: All DAY & NIGHT ONLY Selectable.

BLC (Back Light Compensation): This function is used to counter balance the screen image by increasing the brightness so that a subject which appears dark due to a strong backlight can be displayed in more detail. If you select BLC, a submenu appears where you can make finer adjustments.

- **H-POS / V-POS / H-SIZE / V-SIZE**: Define the position and size of the area of interest by changing the position & size.

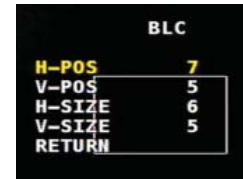

WDR: The WDR (Wide Dynamic Range) function works to correct excessive light within the frame to produce a usable image. When the image has simultaneous bright and dark areas, it makes both areas distinct. If you select WDR, a submenu appears where you can make finer adjustments.

WEIGHT [MIDDLE, HIGH, LOW]: Select the WDR level of the camera.



Note:

- The WDR function might lead to a reduced framerate and “ghost” effects in areas with very bright background.
- Please check effect of DWDR in section 4.11 if you need to further optimize a WDR scene.

4.8 DNR

This function is used to improve the picture quality by filtering the noise which is generated under low bright light conditions. You can set different levels here.



- OFF / LOW / MIDDLE / HIGH selectable

4.9 Day & Night

- This function displays images in color or black and white.
- This function is helpful the camera to adapt to low light conditions.



Here you can choose different settings to control the DAY&NIGHT function.



MODE:

- COLOR:** The camera is always in color mode regardless of the ambient conditions.
- B/W:** The camera is always in Black & White mode regardless of the ambient conditions.
- EXTERN:** Here you can activate the EXTERN function to activate the external Day & Night connector.
- AUTO:** The camera will automatically switch between DAY and NIGHT mode, according to the lighting condition.

ANTI-SAT. : When there is a strong IR LED light, clear images of the background as well as the object can still be obtained by using the ANTI-SAT. function.

EXTERN S/W: It is used when mode is "EXTERN", LOW / HIGH selectable.

AGC THRES [0-20]: Execute the Day/Night switch depending on the AGC level that is used to increase the brightness of the image. Higher values require a darker image to execute the switch.

AGC MARGIN [0-20]: Define the difference between the Day/ Night & Night/Day switch based on AGC THRES. Higher values will increase this distance and can help to prevent continuous switching between Day & Night mode.

DELAY [MIDDLE / HIGH / LOW]: Set the delay time for switching between COLOR and B/W.

RETURN: Select this to save the DAY & NIGHT menu settings and return to the MAIN SETUP menu.

4.10 Image

Here you can optimize the image quality by adjusting different options.



When selecting, the following submenu will appear.



SHARPNESS [1 ~ 10]: Adjusts the image sharpness. If the level goes up excessively, it may affect the video image and generate noise.

GAMMA [0.45 ~ 0.65]: Changes the gamma curve of the camera.

PREDESTAL [0 ~ 20]: Adjusts the black level of the camera.

COLOR GAIN [0 ~ 20]: Changes the color gain of the camera.

MIRROR [ON / OFF]: Mirrors the image horizontally on the screen.

FLIP [ON / OFF]: Flips the image vertically on the screen.

RETURN: Select this to save the IMAGE menu settings and return to the MAIN SETUP menu.

4.11 Special

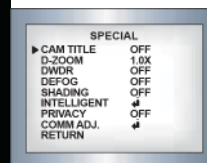

CAM TITLE

- Using UP / DOWN button, select the character to write.
- Using LEFT / RIGHT button, select

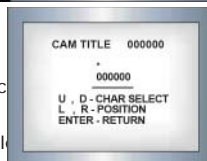

the position to write.

- Press the SET button to return to the SPECIAL menu.

D-ZOOM [1.0x~8.0x]: You can use the up to x8 bi-cubic linear digital zoom.

DWDR [OFF / LOW / MIDDLE / HIGH]: This function illuminates darker areas of an image while retaining the same light level for brighter areas to even out the overall brightness of images with high contrast between bright and dark areas.

DEFOG: Images in extreme environments such as fog or rain or with a very strong luminous intensity have DR (Dynamic Range), lower than normal images.

- MODE** [AUTO / MANUAL / LOW]: Select the defog mode of the camera.
- LEVEL** [MIDDLE / HIGH / LOW]: Select the defog level of the camera.



SHADING [ON / OFF]: Compensates the shading effects of lenses when the lens is set to a very wide angle. This function will reduce the brightness difference between the center and the edges. If you select ON, a submenu appears where you can make finer adjustments.

- WEIGHT** [1%~100%]: You can set different levels here.

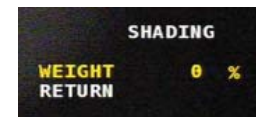

INTELLIGENT



- MOTION** : This function is used to detect moving objects in the monitored area.

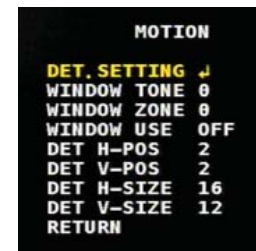

- DET. SETTING: DETECTION SETTING

- **SENSITIVITY** [0 ~ 20]: Motion sensitivity. Smaller value more sensitive.
- **OBJ. KEEP LV** [0 ~ 60]: It has trade-off value maintain motion detection but has less preciseness of detection.
- **MOTION EST.** [0 ~ 21]: MOTION ESTIMATION. If the motion of object disappears, predict where object appear again.
- **SIGNAL OUT** [ON / OFF]: When detected motion, output GPIO signal.



- **WINDOW TONE** [0~6]: Set up the tone of mask area. Motion detection area is excluded mask area.
- **WINDOW ZONE** [0 ~ 3]: Set up the window zone.
- **WINDOW USE** [OFF / ON]: Set up window use.
- **DET H-POS** [0~60]: Set up the horizontal start point of detecting area.
- **DET V-PIOS** [0~40]: Set up the vertical start point of detecting area.
- **DET H-SIZE** [0~41]: Set up the horizontal size of detecting area.
- **DET V-SIZE** [0~33]: Set up the vertical size of detecting area.

ALARM

- **SHAKING** [OFF / ON]: If camera is shaking, output 'Camera Shaking!!!' Alarm.
- **SHAKE SCALE** [0 ~ 20]: Shaking detection sensitivity. Smaller value more sensitive.
- **BRIGHT CHG.** [OFF / ON]: If brightness is changed around camera, output 'Brightness predict where object appear again.'
- **BRIGHT SCL.** [0 ~ 20]: Brightness change detection sensitivity. Smaller value more sensitive.



QUICK ZOOM: If an object is detected, register in Zoom schedule.

- **MOVING** [0 ~ 240]: Execute Zoom-In / Out as much as set frame value.
- **ZOOM IN** [0 ~ 240]: Maintain Zoom state as much as set frame value.
- **STANDBY** [0 ~ 240]: Maintain the state which is no execution of Zoom In / Out as much as set frame value.
- **SYNCHRONOUS** [OFF / ON]: Execute Zoom according to the period.
- **TRACKING** [OFF / ON]: Continued tracking motion area and execute Zoom-In / Out.
- **REPEAT** [OFF / ON]: The area which is already executed Zoom also repeat.

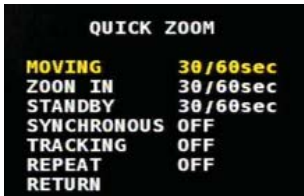

PRIVACY [ON / OFF]: Masks areas that you want to hide on the screen.

The camera can activate up to 16 privacy masks. Switch between ON and OFF to activate or deactivate this function.

- **ZONE NUM** [0 ~ 15]: Select a mask out of the 16mask areas and set the options below for the selected mask.
- **ZONE DISP** [ON / OFF]: Choose ON to activate privacy masks and press OFF to deactivate masks.
- **H-POS** [0 ~ 60]: Define the horizontal start position of the privacy mask.
- **V-POS** [0 ~ 40]: Define the vertical start position of the privacy mask.
- **H-SIZE** [0 ~ 40]: Define the horizontal size of the privacy mask.
- **V-SIZE** [0 ~ 40]: Define the vertical size of the privacy mask.
- **Y LEVEL** [0 ~ 20]: Define the brightness of the mask color.
- **CR LEVEL** [0 ~ 20]: Define the red amount of the mask color.
- **CB LEVEL** [0 ~ 20]: Define the blue amount of the mask color.

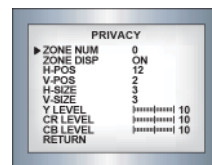

COMM ADJ.: This function sets up the camera communication status when controlling the camera through an external control device.

- **CAM ID:** Determines the camera's identification number (between 0 and 255).
- **BAUD RATE:** Select 2400 / 4800 / 9600 / 57600 / 115200 bps.

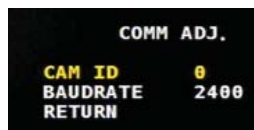

RETURN: Select this to save the SPECIAL menu settings and return to the MAIN SETUP menu.

4.12 System



VIEW ANGLE [WIDE 4:3 / WIDE 16:9 / NORMAL]: Choose a view angle.

CVBS [PAL / NTSC]: Select the video format that matches the present TV system.

LANGUAGE: You can select the menu language according to your requirements

RESET: All settings will be restored to factory default. Please press the SET button until 'PUSHING' displays.

RETURN: Return to the MAIN SETUP menu.

4.13 Exit

Press the Set button in the exit menu to save the current settings and exit the Set Up menu.



5. Troubleshooting

If there are problems with the camera operation, check the tables below.

If the problem persists, please contact the agent who supplied the product.

Problems	Troubleshooting
Nothing appears on the screen.	<ul style="list-style-type: none"> • Check the power connection. • Check the video signal line connection.
The video image is not clear.	<ul style="list-style-type: none"> • Make sure that the lens is clean. • Clean the lens with a clean lint free cloth or brush. • Adjust the contrast control on the monitor. • Make sure that the screen is not exposed directly to a bright light. Re-position the camera if necessary. • Re-adjust the back focus of the camera.
The screen is dark.	<ul style="list-style-type: none"> • Adjust the contrast control of the monitor. • If there is an intermediate device, check the connections. • Check if an auto iris lens is being used and if necessary adjust the brightness level.
There is a problem with the camera operation. The camera surface is too hot and black stripes appear on the screen.	<ul style="list-style-type: none"> • Please check if an appropriate power source to the camera complies with the manufacturer's standard requirement, or if the voltage is fluctuating. • Check for ground loops.
Colors are not quite right.	<ul style="list-style-type: none"> • Check the 'WHITE BAL' setting.
The screen is flickering.	<ul style="list-style-type: none"> • Check if the camera is facing directly into sunlight or fluorescent light. Try adjusting the HLC or WDR controls. • Check if an auto iris lens is being used. • Check the connection of the lens connector cable.

6. Specifications

Electrical	24C1.3XW
Image Sensor	SONY 1/3" 1.3MP CMOS Sensor
Scanning System	2:1 Interlace
Scanning Frequency	NTSC: Horizontal: 15.734 KHz, Vertical: 59.94 Hz PAL: Horizontal: 15.625 KHz, Vertical: 50.00 Hz
Resolution	800 TV lines (Color), 900 TV lines (B/W)
Signal to Noise Ratio	52dB (AGC Off, ON)
Min. Illumination	0.1Lux (Color), 0.01Lux (B/W)
Iris Control	Electronic/ DC auto iris
Shutter Speed	1/60 ~ 1/160,000 sec., 1/50 ~ 1/160,000 sec.
Power Supply	12VDC +/- 10%

Environmental

Operating Temperature	-10°C ~ 50°C (14° F ~ 122° F)
Operating Humidity	30% up to 80% RH
Storage Temperature	-20°C ~ 60°C (-4° F ~ 140° F)
Storage Humidity	20% to 90% RH

Mechanical

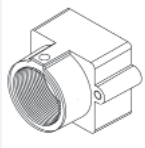
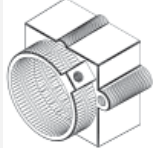
Dimensions W x H x D	32mm x 32mm (1.26" x 1.26")	
Lens mounts	Replace "X" in model number with desired lens mount option:	
Example: Change 24C1.3XW to 24C1.35W to select an M-12 Board Mount.	5 = Metal M-12 Board	6 = Metal M-14 Board
		

7. Contact Information

For technical assistance with this product, please contact the supplier from whom the product was purchased.

For OEM inquiries, contact Videology® Imaging Solutions:

Americas, Middle East, Far East & Australia:

Videology® Imaging Solutions Inc.
37M Lark Industrial Parkway
Greenville, RI 02828
USA
Tel: (401) 949-5332
Fax: (401) 949-5276

Europe & N. Eurasia:

Videology® Imaging Solutions Europe B.V.
Neutronenlaan 4
5405 NH Uden
The Netherlands
Tel: +31 (0) 413-256261
Fax: +31 (0) 413-251712

Please visit our website: www.videology.com



VIDEOLOGY IMAGING SOLUTIONS is an ISO 9001 registered video camera developer and manufacturer serving industrial, machine vision, biometric, security, and specialty OEM markets. Videology designs, develops, manufactures, and distributes video, image acquisition, and display technologies and products to OEMs worldwide.