

VIDEOLOGY®

IMAGING SOLUTIONS INC.

Application Note

20/21Z704 USB Color Camera

Information may change without notice.

This document provides technical information for the user. Videology reserves the right to modify the information in this document as necessary. The customer should make sure that they have the most recent manual version. Videology holds no responsibility for any errors that may appear in this document.

Videology Imaging Solutions, Inc. USA
37M Lark Industrial Parkway
Greenville, RI 02828
Tel: 401-949-5332
Fax: 401-949-5276



Videology Imaging Solutions, B.V. Europe
Liessentstraat 2B
NL-5405 AG Uden, The Netherlands
Tel: +31 (0) 413-256261
Fax: +31 (0) 413-251712

Doc # APN 20/21Z704USB	Issue Date: 05/11/2007
Revision: C	Page 1 of 23

Table Of Contents

- 1. Specifications..... 3
 - 1.1. Lens (Canon) 3
 - 1.2. Camera Function 3
 - 1.3. Dimensions 5
 - 1.4. Optional Accessories 5
- 2. Specifications (for USB)..... 6
 - 2.1. Features 6
 - 2.2. PC Minimum System Requirements 6
 - 2.3. Software Download 6
 - 2.4. Technical Specifications 7
- 3. Measurement Specifications 8
- 4. Environment Condition And Test 8
- 5. Interface 8
- 6. Recommended Circuit For Local Controls..... 10
- 7. Lens Test Condition 13
 - 7.1. Zoom 13
 - 7.2. Focus 13
 - 7.3. Auto Iris 13
- 8. Appendix 1 14
 - 8.1. OSD (On Screen Display) Format 14
 - 8.1.1. Decryption 15
 - 8.2. Menu Descriptions..... 16
 - 8.2.1. Menu Format 16
 - 8.2.2. Using MENU..... 16
 - 8.3. Menu Description 16
- 9. Appendix 2 18
 - 9.1. Measurement Conditions 18
 - 9.2. Measuring System 19
 - 9.3. Measurment Procedure 20
 - 9.4. Color Reproduction..... 21
 - 9.5. Luminance S/N 22
 - 9.6. Horizontal Resolution..... 22
 - 9.7. Low Luminance Sensitivity 22
- 10. Contact 23

1. Specifications

Signal System	NTSC (20Z704USB)	PAL (21Z704USB)	REMARKS
Scanning System	2:1 Interface		
Scanning Frequency (H)	15.734 KHz	15.625 KHz	
Scanning Frequency (V)	59.94 Hz	50 Hz	
Image Sensor	¼ Inch Solid State Interline CCD Image Sensor		SONY
Total Pixels No.	811 (H) X 508 (V) 410K	795 9H) X 596 (V) 470K	
Effective Pixels No.	768 (H) X 494 (V) 380K	752 (H) X 582 (V) 440K	

“ **Bold: Default Mode** ”

1.1. Lens (Canon)

F1.4 ~ 2.8, f = 4.0 ~ 64.0 mm, x16 Zoom Video Auto Focus
 Angle of View H: 47°(WIDE), 3° (TELE)

Zoom Durability

More than 500k at Room Temperature

Focus Durability

More than 500k at Room Temperature

Iris Durability

More than 500k at Room Temperature

Focus Length

∞ ~ 1.0m (Tele)~0.01m (Wide)

Signal Process

Digital Signal Process

Sync System

Internal

1.2. Camera Function

Optical Zoom

TELE ~ WIDE (Zoom Speed: 6 sec)

Digital Zoom

ON / Off (X8 times)

Video Focus

Auto / Manual (NEAR ~ FAR) / Push Auto

Manual Mode

Zoom Start



Manual (AF Action is activated for a moment before focus stops)

Manual

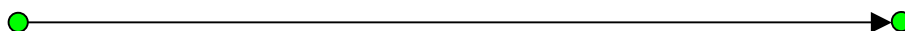

White Balance

Auto / Indoor / Outdoor / Push Auto / Manual (R&B Gain Level UP/Down)
 Special (R or B Gain Level Control)

Doc # APN 20/21Z704USB	Issue Date: 05/11/2007
Revision: C	Page 3 of 23

Shutter Speed

Auto / Manual (1/60 ~ 1/ 10000 (NTSC) / 1/50 ~ 1/10000 (PAL))

Iris Control

Auto / Manual (Manual Iris Level: UP ~ Down)

Gain Control

Auto / Manual (Auto Gain Control: UP ~ Down)

Sharpness

Manual (Sharpness UP ~ Down)

Brightness

Manual (Brightness UP ~ Down)

Negative

Off / On (Negative Level UP ~ DOWN)

OSD Function

On / Off English / Chinese (See an Annexed Document " APPENDIX 1 ")

Flickerless

Off / On (1 / 100 sec Shutter Set (NTSC) / 1/120 sec Shutter Set (PAL))

Back Light

Off / On/ Auto

Video Output Level

NTSC	Video Level	0.714 ± 0.07V (100 ± 10 IRE)
	Sync Level	0.286 ± 0.035V (40 ± 10 IRE)
	Burst Level	0.286 ± 0.035V (40 ± 10 IRE)
PAL	Video Level	700 ± 70 mV
	Sync Level	300 ± 35 mV
	Burst Level	300 ± 35 mV

Color Reproduction

COLOR		RED	BLUE	YELLOW	BURST
NTSC	Amplitude (%)	200 ± 40%	130 ± 40%	115 ± 40%	100% (Base)
	Phase (°)	103 ± 20°	345 ± 20°	170 ± 20°	180° (Base)
PAL	Amplitude (%)	200 ± 40%	130 ± 40%	115 ± 40%	100% (Base)
	Phase (°)	103 ± 20°	345 ± 20°	170 ± 20°	135° (Base)

Horizontal Resolution

More than 470 Lines

Luminance S/N

More than 48dB

SensitivityTyp. 1Lux ---- At Signal Level 30 IRE
(LENS-F: F = 1.4 (WIDE) AGC Gain: Max)**Supplied Voltage**

9.0V ~ 15.0V (Recommendation 12.0 V ± 0.5 V .)

Doc # APN 20/21Z704USB	Issue Date: 05/11/2007
Revision: C	Page 4 of 23

Supplied Current

210 mA (Steady-state)

350 mA (Max) ----- While zooming and focusing

Power consumption

5.4 W (Max)

1.3. Dimensions

(W × H × D) 58.8mm × 56.9mm × 87.8mm without a converter lens

Weight

225g (Approx.)

Body Color

Nickel

Remote Controller and Receiver Support

Model Option

1.4. Optional Accessories

- 5 pin Harness A'Y (For Communication and Analog Audio Input) {option}
- 10 Pin Harness A'Y (For Control)
- 3 Pin Harness A'Y (For Remote Controller)
- 5 Pin USB Cable A'Y (For USB Operation)
- Converter Lens: 35Cm ~ 49Cm
- Converter Lens: 25Cm ~ 35Cm

Doc # APN 20/21Z704USB	Issue Date: 05/11/2007
Revision: C	Page 5 of 23

2. Specifications (for USB)

Signal System	NTSC 20Z704USB	PAL 21Z704USB	REMARK
Full motion video	15 frame/sec (Resolution 640 x 240) (VGA display 640 x 480)	15 frame/sec (Resolution 640 x 240) (VGA display 640 x 480)	
	30 frame/sec (CIF resolution 320 x 240)	25 frame/sec (CIF resolution 352 x 288)	
Still image capture	640X480 (VGA) 320X240 (CIF)	768X576 (VGA) 352X288 (CIF)	
USB Bandwidth	7.5Mbps		
OS	Microsoft Windows 98, ME, 2000, XP		

2.1. Features

- Full motion video
 - 30 fps at CIF resolution Video Capture via USB
 - Audio input for simultaneous audio capture via USB (option)
 - VGA (640X480) resolution still image capture
 - Hot plug-and-play operation
 - WDM streaming driver fully compatible with Microsoft DirectShow.
 - Compatible with Microsoft Windows 98, ME, 2000, XP
 - Compatible with popular video conferencing software and Video for Windows applications.
 - Compatible with TWAIN applications for still image capture
 - Self Powered (Input 12V, Max.450mA)
 - USB Bandwidth utilization is adjustable (7.5Mbps)
- Camera/Feature Control (For custom application software, API functions are needed. Please download at <http://www.videologyinc.com/>)

2.2. PC Minimum System Requirements

- 16bit VGA Display Adapter
- PC with a Pentium Processor 233MHz with MMX, and 32Mb of memory
- USB Port
- Microsoft Windows 98, ME, 2000, XP

2.3. Software Download

Drivers for camera models 20/21Z704USB and 20/21Z704USB-SYS (model number **SFT-03005**) can be downloaded at the following address

<http://www.videologyinc.com/downloadVIEWERS/SFT-03005v3.2.4.zip>

For now, as in the past, our video engineers and technical support specialists are available to provide telephone, e-mail, and custom WEB-based support to current OEM customers.

Contact U.S. technical support staff by email at: support@videologyinc.com

Contact European technical support staff by email at: support@videology.nl

Doc # APN 20/21Z704USB	Issue Date: 05/11/2007
Revision: C	Page 6 of 23

2.4. Technical Specifications

Video Capture	NTSC	15 frames/sec at VGA size (640 x 240 Resolution) (640 x 480 Display) 30 frames/sec at CIF size (320 x 240)	
	PAL	15 frames/sec at VGA size (640 x 240 Resolution) (640 x 480 Display) 30 frames/sec at CIF size (352 x 288)	
High resolution still image capture	NTSC	640 x 480 (VGA), 320 x 240 (CIF) RGB 24 Bit	
	PAL	768 x 576 (VGA), 384 x 288 (CIF) RGB 24 Bit	
		Note: For custom application software, API functions are needed. Please download at http://www.videologyinc.com/	
Image formats	RGB 16,24 Bits, YUV422, YUV12		
Image resolution	640 x 480, 320 x 240		
Software Drivers	WDM device driver VFW compliant TWAIN compliant	* Audio driver supports audio preview through sound card. (Option)	
	<p>*CAUTION!!</p> <p>There may be conflicts with pre-existing USB drivers from other video devices. Check whether this is on system. Removal may be necessary. Audio drivers that are improperly installed or missing their device may also cause conflicts. In such a case, remove driver or connect device.</p>		
USB Standard	USB 1.1 Compliant		
USB Bandwidth	7.5 Mbps		

3. Measurement Specifications

*Standard Measurement Condition and Measurement Procedure
See " APPENDIX 2 "

4. Environment Condition And Test

Operating Condition

Temperature -10°C ~ 50°C (Recommended: -5°C ~ 40°C)
Humidity 10% ~ .85%

Storage Condition

Temperature -20°C ~ 60°C
Humidity 0% ~ 90%

High Temperature storage Test

Leave the camera packed at a temperature of 60°C for 72 Hours. Then bring it to room temperature and leave it for 8 Hours. There should be no problem in performance.

Low Temperature storage Test

Leave the camera packed at a temperature of -20°C for 72 Hours. Then bring it to room temperature for 8 Hours. There should be no problem in performance.

5. Interface

Pin Assignment

J3, 10 Pin Connector; Maker Molex/Yeon-ho, 12505WR-10A00

* Is the color of the cable. (If offered)

PIN No.	NAME	I/O	* Color	Note
1	C - OUT	Output	White	
2	Y - OUT	Output	Gray	
3	GND (For Video)		Violet	
4	VIDEO OUT	Output	Blue	
5	DC IN (ALIVE)	Input	Green	9 V ~ 15 V (Recommendation 12±0.5 V)
6	KEY 1	Input	Yellow	
7	KEY 2	Input	Orange	
8	DD ON	Output	Red	For Video Presenter
9	POWER ON	Input	Brown	
10	GND (For Power)		Black	

Pin Assignment

J2, J10, 3 Pin Connector; Maker Molex/Yeon-ho, 12505WR-03A00: R/C Receiver

J2

Pin No.	NAME	I/O
1	DC OUT	Output
2	GND (For R/C)	
3	R/C DATA	Input

J10

Pin No.	NAME	I/O
3	DC OUT	Output
2	GND (For R/C)	
1	R/C DATA	Input

Doc # APN 20/21Z704USB	Issue Date: 05/11/2007
Revision: C	Page 8 of 23

Pin Assignment

J404, 5 Pin Connector; Maker Molex/Yeon-ho, 12505WR-05A00

J401

* is the color of the cable. (If it offered)

PIN No.	NAME	I/O	* Color	Note
1	Audio IN	Input	Yellow	Analog Audio Input
2	GND (For Audio)		Black	
3	GND (For Data)		Black	
4	TD (For RS- 232C)	Output	Brown	CMOS Level 5V (Low: Max 0.8V, High: Min 3.7V)
5	RD (For RS-232C)	Input	Red	CMOS Level 5V (Low: Max 0.8V, High: Min 3.7V)

* The 10 pin Connector over the camera module is used for manufacturing. (Not for user)

Pin Assignment

(J402, 5 Pin Connector; Maker Molex/Yeon-ho, 12505WR-05A00)

J401

* is the color of the cable. (If it offered)

PIN No.	NAME	I/O	* Color	Note
1	Power		RED	USB VCC
2	D-		White	USB Data-
3	D+		Green	USB Data+
4	GND (For data)		Black	USB GND
5	GND (For shield)		Black	USB SHIELD GND

6. Recommended Circuit For Local Controls

Selectable KEY Function

NO.	Function	NO.	Function
1	Tele (Normal Speed)	16	Backlight On / Off
2	Wide (Normal Speed)	17	Color / Black
3	Tele (High Speed)	18	Initial Set
4	Wide (High Speed)	19	Power On / Off
5	Focus Auto / Manual	20	Shutter Speed
6	Digital Effect	21	Menu On / Off
7	Manual Focus, Far	22	Flickerless On /Off
8	Manual Focus, Near	23	Image Mirror On /Off
9	WB Mode Auto / Push Auto	24	Language English / Chinese (Korean)
10	WB Push Auto On	25	Mirror
11	Brightness (Negative) Control (+)	26	Red control
12	Brightness (Negative) Control (-)	27	Blue control
13	Sharpness Control (+)	28	SNAPSHOT
14	Sharpness Control (-)	29	
15	Positive / Negative	30	

Figure 1. KEY Function

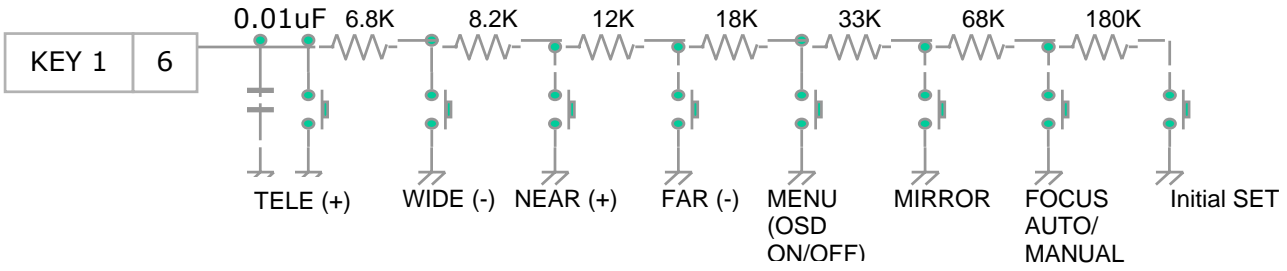

* If you keep pressing MENU over 2 seconds, OSD will be off.
Menu mode will be displayed again once Menu is pressed.

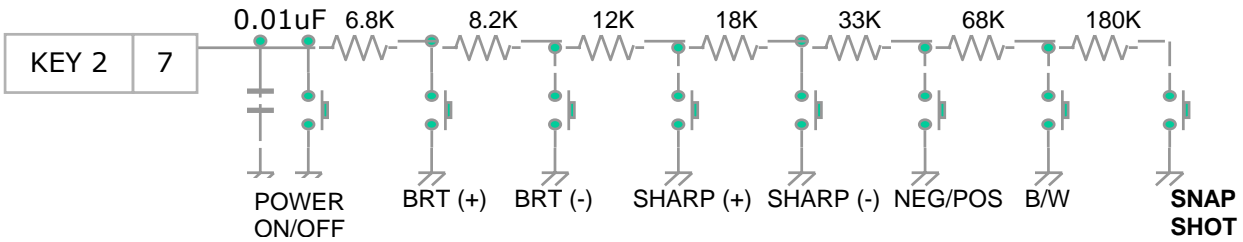

Figure 2. POWER ON

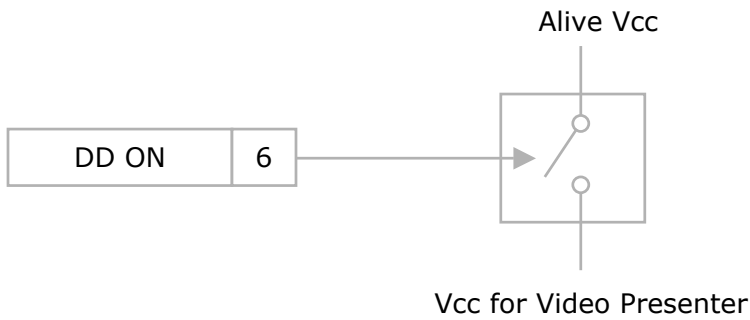
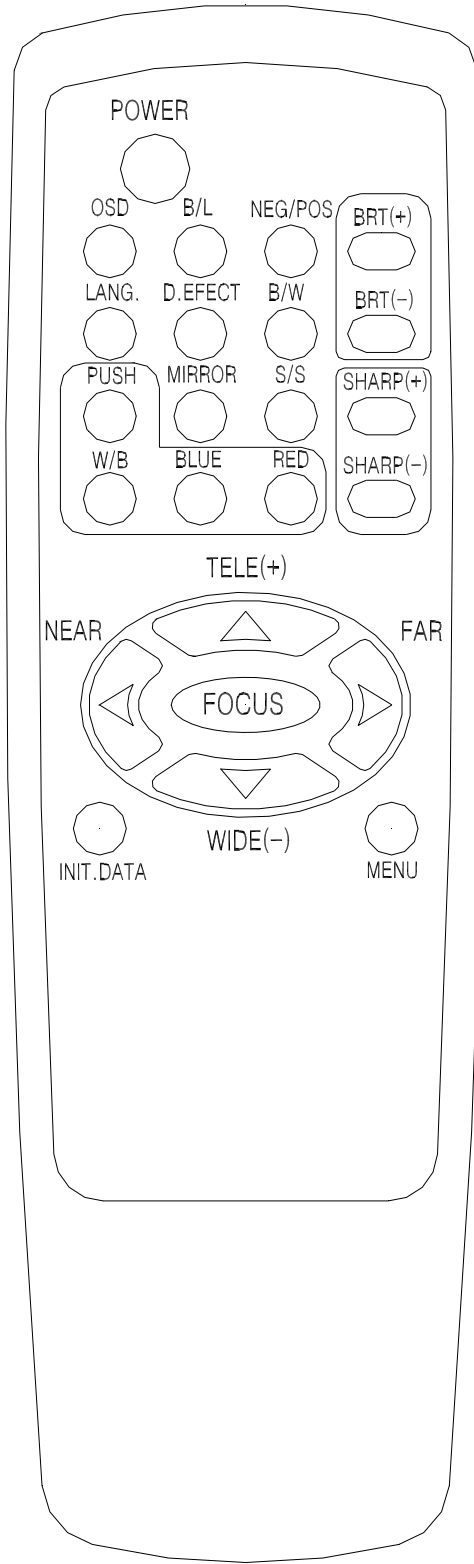

Figure 3. Power On Function

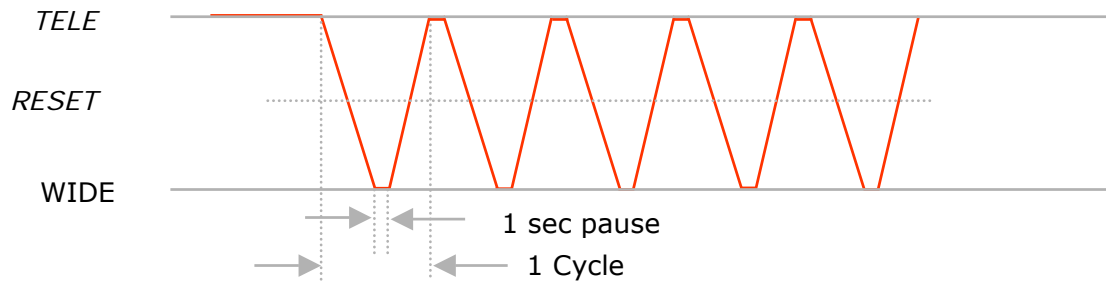

Figure 4. Remote Controller



7. Lens Test Condition

7.1. Zoom



7.2. Focus

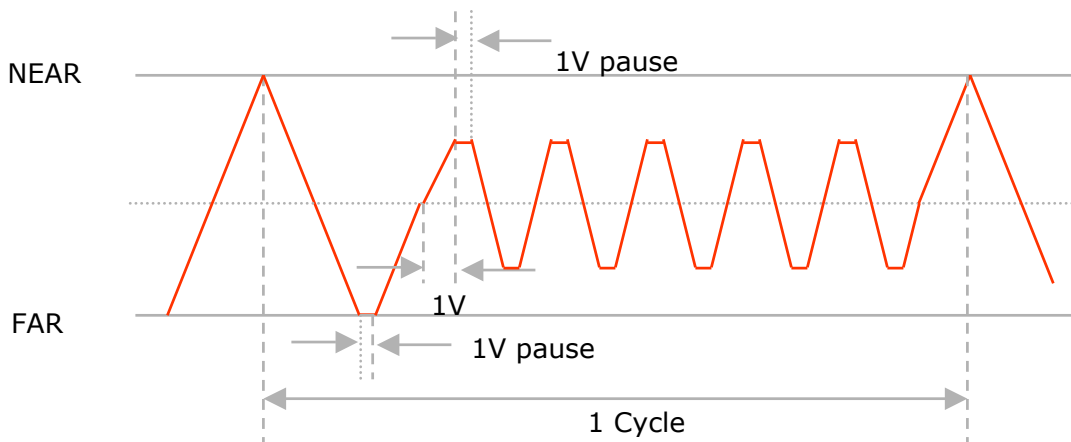

7.3. Auto Iris

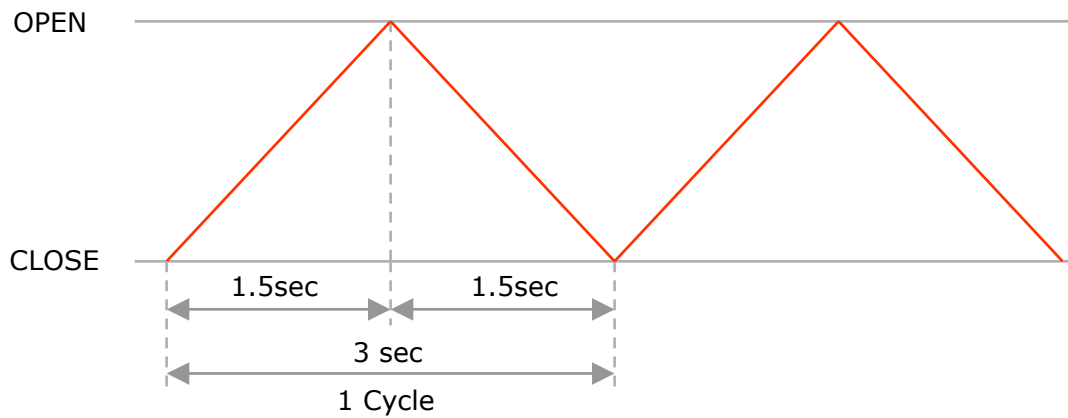





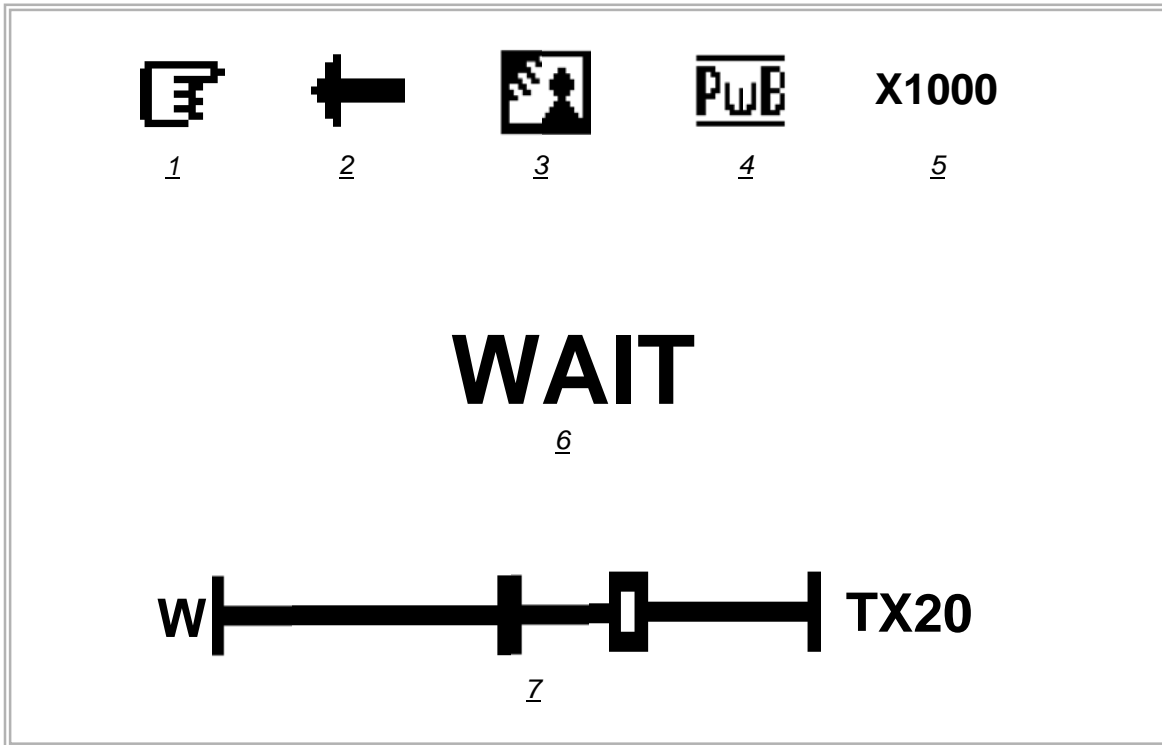

8. Appendix 1

8.1. OSD (On Screen Display) Format

OSD Display Position

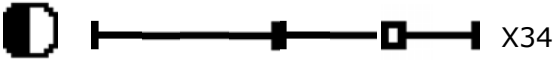

8.1.1. Decryption

	FUNCTION	OSD FORMAT	DESCRIPTION	REMARKS
1	Focus Mode	Non Display	Focus Auto Mode	
			Focus Manual Mode	
2	Mirror Mode	Non Display	Mirror Mode Off	
			Mirror Mode On	
3	Back Light	Non Display	Back Light Off	
			Back Light On	
4	WBC Mode	Non Display	White Balance AUTO	
			Push Auto White Balance: In this mode "Push Key" pressed, the white balance tracks automatically (PWB Auto Mode). "Push Key" released, the white balance is preserved with the current settings (PWB Manual Mode).	
	FUNCTION	OSD FORMAT	DESCRIPTION	REMARKS
5	Shutter Speed	Non Display	Normal Shutter (NTSC:1/60) (PAL:1/50)	
		1/125 · · · 1/10000	8 variable steps. (Can be set to 28 steps by Manufacture Option)	
6	Wait Mode	WAIT	Indicates the camera stand-by mode until the camera power turns ON.	
7	Zoom Display	<p>W  T X10</p> <p>; In case of 16X Zoom; Optical Zoom only mode ; (Current Zoom : 10X)</p> <p>W  T X20</p> <p>; In case of 128X Zoom; Digital Zoom 2X mode ;(Current Zoom: 20X)</p>		
	Sharpness Adjustment Mode DISPLAY	 X10		
	Brightness Adjustment Mode DISPLAY	 X34		

* The OSDs of 1,2,3,4,5,6,7 disappear 5 sec later.

8.2. Menu Descriptions

8.2.1. Menu Format

MENU	
1	IMAGE MIRROR OFF (ON)
2	NEG / POS POS (NEG)
3	COLOR ON (OFF)
 4	WB CONTROL AUTO
	(PUSH AUTO)
5	BRIGHTNESS 18
6	SHARPNESS 10
7	INIT DATA OFF (ON)
END	

8.2.2. Using MENU

1) Menu Mode

In order to display the MENU on the screen, Press the MENU key.

If you keep pressing MENU over 2 seconds, OSD will be off.

Menu mode will be displayed again once Menu is pressed.

2) Menu Item selection Mode

Position Hand Mark to each ITEM you want to change by using Wide and Tele Keys.

3) Menu Data Change Mode

Press the NEAR and FAR key. Then the right side of selected ITEM will blink and the values can be changed by using Tele and Wide keys.

4) Press the NEAR and FAR key again to return to Mode (2).

5) To escape from Menu Mode, press Menu key again in Mode (2).

Remarks: NEAR and FAR Key Switches Menu Item selection Mode (2) and Menu Data change Mode (3).

8.3. Menu Description

Image Mirror

When IMAGE MIRROR is ON state, the image is displayed in the opposite direction.

Neg/Pos

Use to change NEGATIVE and POSITIVE mode.

ON: Negative Mode, OFF: Positive Mode.

Color

ON: Color Mode, OFF: B / W (Monochrome Mode).

WB Control Mode

Use to change White Balance Mode.

- AUTO: WB Range 2800⁰K ~ 8000⁰K.

PUSH AUTO: In this Mode you can adjust White point by using PUSH AUTO Key. ()

Doc # APN 20/21Z704USB	Issue Date: 05/11/2007
Revision: C	Page 16 of 23

Brightness

Use to change the brightness level of scene (0 ~ 48)

Use to change Negative level

Sharpness

Use to change the contour of scene (0 ~ 15).

Init Set

Turn the initial mode ON, the changed data are renewed to manufacturer setting.

(The data are initialized to its shipping condition)

Doc # APN 20/21Z704USB	Issue Date: 05/11/2007
Revision: C	Page 17 of 23

9. Appendix 2

9.1. Measurement Conditions

Standard Measurement Conditions

Supplied Voltage	DC 12V \pm 0.5 V
Ambient Temperature	23°C
Humidity	60 % RH
Measurement Fixture	Video output, DC input, RS-232C level Convert (5Vpp - > 12Vpp)
Power Supply	12V \pm 0.5 V
Color Monitor	CMM20 - 11, Shibasoku or Equivalent
Monochrome Monitor	More than 800 TV Lines Horizontal Resolution
Waveform Monitor/ Vector Scope	1720A, Tektronix (NTSC / EIA) or Equivalent 1730A, Tektronix (PAL / CCIR) or Equivalent
S / N (Signal to Noise) Meter	VN31AX, Shibasoku (NTSC/PAL/EIA/CCIR) or Equivalent
Illumination Meter / Color Temperature Meter	XY-1 / CL-100, Minolta Camera or Equivalent
Light Box	Dai Nippon Printing Co. - Color Temperature 3200. K \pm 100 . K - Illumination More than 2000 Lux
Test Charts	(Transparent Chart) Color Bar Chart, Dai Nippon Printing Co. Gray Scale Chart, Dai Nippon Printing Co. (Gamma 0.45) Resolution Chart, Dai Nippon Printing Co. (Reflective Chart) Gray Scale Chart, Murakami Color Research Lab
Light Source	Halogen Lamp (with Dimmer Switch) - Color Temperature 3200 ° K \pm 100 ° K - Illumination Variable with Dimmer
Color Temperature Filter	LB 140, Hoya or Kenko or Equivalent (Color Temperature Conversion Filter)
Adjustment PC	With Serial Port 1 or 2
RS-232C Cable	Each Terminal Connector (D-Sub 9 Pin)

9.2. Measuring System

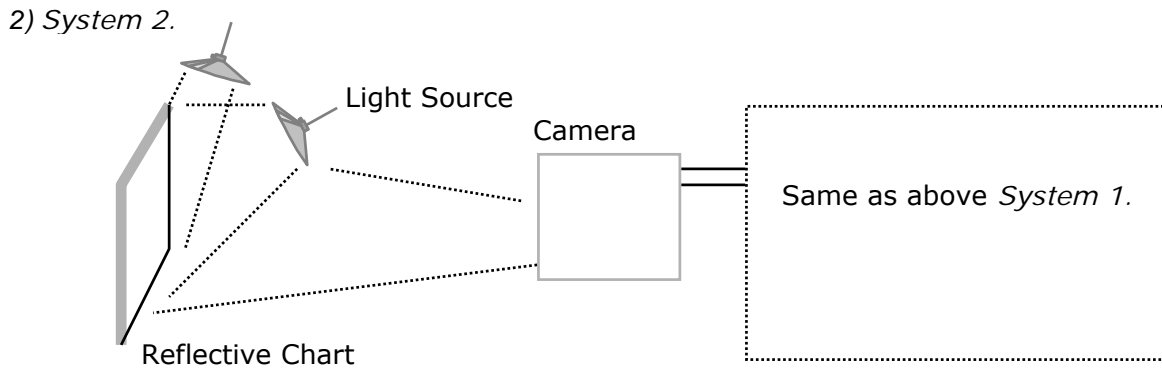
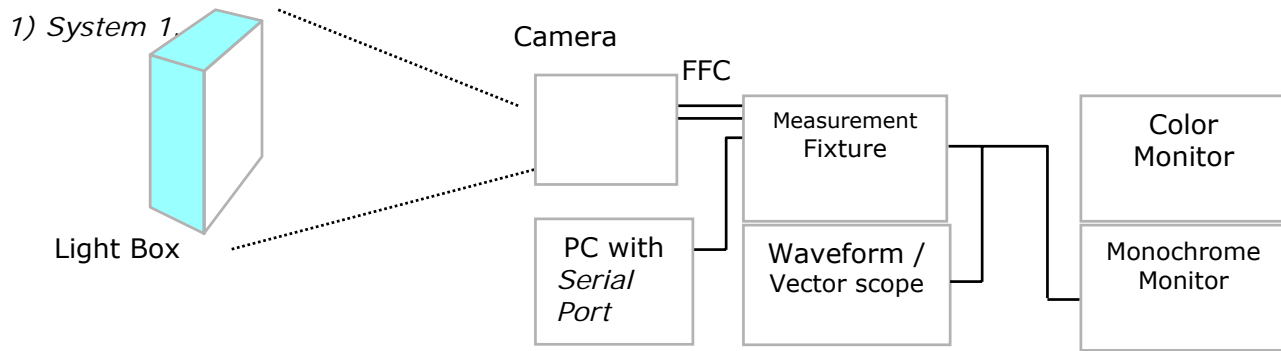

9.3. Measurement Procedure

VIDEO OUTPUT LEVEL

TEST CONDITIONS	Refer to " MEASUREMENT CONDITIONS"
-----------------	------------------------------------

MEASURING SYSEM	System 1.
-----------------	-----------

PROCEDURE:

1. Shoot the gray scale chart, and zoom WIDE or TELE to fit a scene of monitor fully by PC.
2. Measure the video output level on the waveform monitor
(Before the above measurement, Measure the SYNC and BURST level)

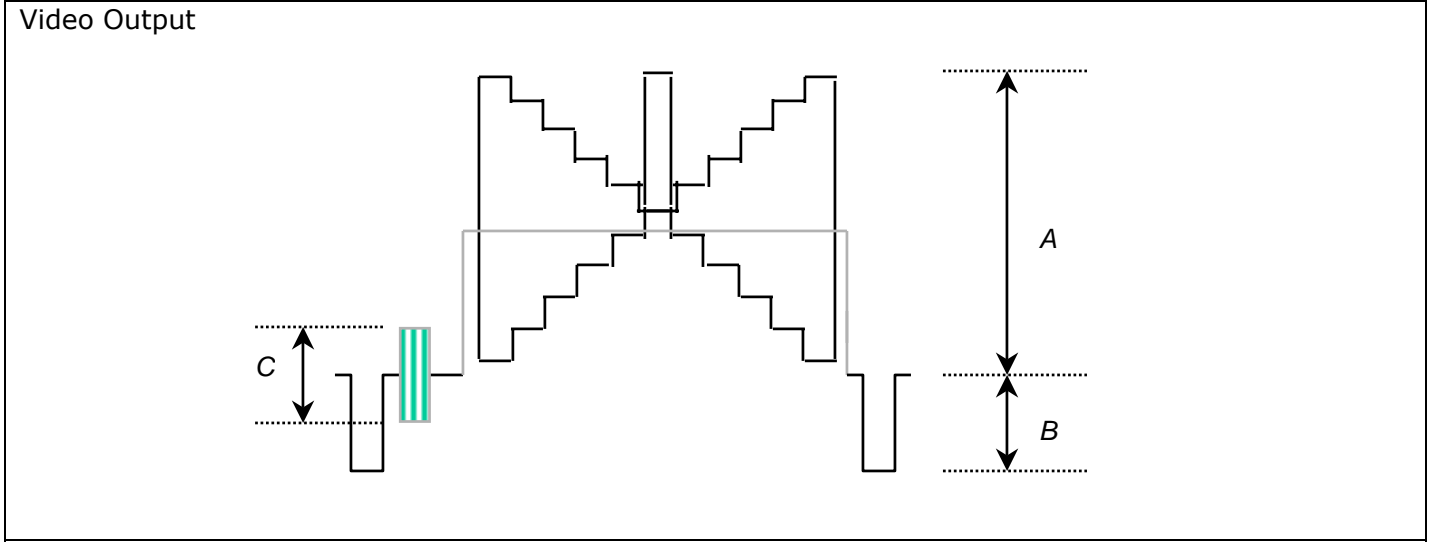

SPECIFICATION:

NTSC	Video Level A	100 ± 10 IRE
	Sync Level B	40 ± 5 IRE
	Burst Level C	40 ± 5 IRE
PAL	Video Level A	700 ± 70 mV
	Sync Level B	300 ± 35 mV
	Burst Level C	300 ± 35 mV

9.4. Color Reproduction

TEST CONDITIONS	Refer to "10.1. MEASUREMENT CONDITIONS"
MEASURING SYSTEM	System 1.

PROCEDURE:

1. Image the color bar chart, and Zoom WIDE or TELE completely fill the monitor with the target.
2. Measure the color amplitude and color phase on the vector scope of Red, Blue, Yellow. (Before the above measurement, Adjust the burst amplitude and phase on the vectorscope so that the burst level becomes 100% and its phase becomes 180 ° (NTSC) (135 ° PAL)

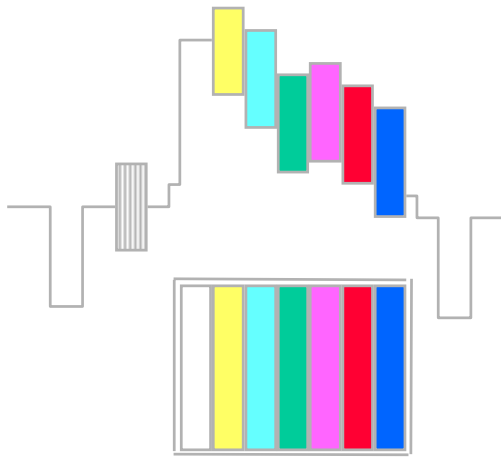

Video Output Waveform

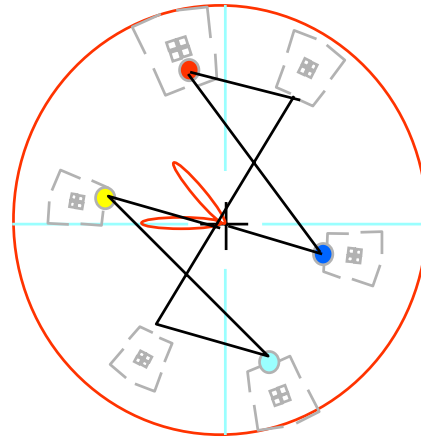

Video Output Color Vector

SPECIFICATION:

COLOR		RED	BLUE	YELLOW	BURST
NTSC	Amplitude (%)	200 ± 40%	130 ± 40%	115 ± 40%	100%
	Phase (°)	103 ± 20°	345 ± 20°	170 ± 20°	180°
PAL	Amplitude (%)	200 ± 40%	130 ± 40%	115 ± 40%	100%
	Phase (°)	103 ± 20°	345 ± 20°	170 ± 20°	135°

9.5. Luminance S/N

TEST CONDITIONS	Refer to "10.1. MEASUREMENT CONDITIONS
MEASURING SYSTEM	System 1.
PROCEDURE:	
<ol style="list-style-type: none"> Shoot the light box, and zoom WIDE or TELE to fit a scene of monitor fully by PC The noise meter settings are; <ul style="list-style-type: none"> Input level : Preset High Pass Filter : 100KHz Low Pass Filter : 4.2 MHz Sub-carrier Trap : On Weighting : On Sag & Hue Comp. : Optimum Measure the maximum S/N on the noise meter. 	
SPECIFICATION:	
NTSC	: More than 48 dB
PAL	: More than 48 dB

9.6. Horizontal Resolution

TEST CONDITIONS	Refer to "10.1. MEASUREMENT CONDITIONS
MEASURING SYSTEM	System 1.
PROCEDURE:	
<ol style="list-style-type: none"> Image the resolution chart, and Zoom WIDE or TELE completely fill the monitor with the target Adjust the brightness and contrast of the B/W monitor so that each step of the gray scale target can be observed. Change the scan size of monitor to underscan. The reference arrows on the resolution chart are positioned at the edge of the underscanned picture. Change the scan size of monitor from underscan to overscan. Measure the maximum horizontal resolution on the picture. 	
SPECIFICATION:	
More than 480 TV Lines (High Resolution)	
More than 380 TV Lines (Normal Resolution)	

9.7. Low Luminance Sensitivity

TEST CONDITIONS	Refer to "10.1. MEASUREMENT CONDITIONS
MEASURING SYSTEM	System 2.
PROCEDURE:	
<ol style="list-style-type: none"> Shoot the gray scale chart (reflective), and Zoom WIDE fully by PC. Adjust the brightness of the light source by using the dimmer switch so that the white peak level of the chart becomes 30 IRE (NTSC), (210 mV, PAL) on the waveform monitor. Measure the level of illumination by using the illumination meter. 	
SPECIFICATION:	
NTSC (Normal)	: 0.5 Lux (30 IRE)
PAL (Normal)	: 0.5 Lux (210 mV)

10. Contact

To contact Videology Imaging Solutions:

North / South America:

Videology Imaging Solutions Inc.
37M Lark Industrial Parkway
Greenville, RI 02828
USA
Tel: (401) 949-5332
Fax: (401) 949-5276

Europe:

Videology Imaging Solutions Europe
Liessentstraat 2-B
NL-5405 AG Uden
The Netherlands
Tel: +31 (0) 413 256 261
Fax: +31 (0) 413 251 712

Please also visit our WEB-site at:

<http://www.videologyinc.com/>

Please note that data in this application note is subject to change without notification!

VIDEOLOGY IMAGING SOLUTIONS is an ISO 9001 registered video camera developer and manufacturer serving industrial, machine vision, biometric, security, and specialty OEM markets. Videology designs, develops, manufactures, and distributes video, image acquisition, and display technologies and products to OEMs worldwide.

Doc # APN 20/21Z704USB	Issue Date: 05/11/2007
Revision: C	Page 23 of 23