

VIDEOLOGY®

IMAGING SOLUTIONS INC.

17" TFT LCD Module USER MANUAL Preliminary

45S17



Information may change without notice.

This document provides technical information for the user. Videology reserves the right to modify the information in this document as necessary. The customer should make sure that they have the most recent manual version. Videology holds no responsibility for any errors that may appear in this document.

Videology Imaging Solutions, Inc. USA



37M Lark Industrial Parkway
Greenville, RI 02828
Tel: 401-949-5332
Fax: 401-949-5276

Videology Imaging Solutions, B.V. Europe

Liessentstraat 2B
NL-5405 AG Uden, The Netherlands
Tel: +31 (0) 413-256261
Fax: +31 (0) 413-251712

Doc # INS-45S17	Issue Date: 02/02/07
Revision: A	Page 1 of 12

Table Of Contents

1.	Warning	3
2.	Precautions	3
2.1.	Safety	3
2.2.	Installation	3
2.3.	Cleaning	3
3.	Federal Communications Commission (FCC) Statement.....	4
4.	Functional Block Diagram	5
5.	Module Connector P in Configuration	6
6.	Inspection Standard.....	7
6.1.	Inspection environment conditions	7
6.2.	The viewing line should be perpendicular to the surface screen.....	7
7.	Specification	8
8.	The Reference of Input Application.....	9
8.1.	Drive Board w/Input Connectors	9
8.2.	Function Key Board	9
9.	Mechanical Characteristics	10
10.	Contact	12

1. Warning

TO REDUCE THE RISK OF FIRE OR ELECTRIC SHOCK:
DO NOT EXPOSE THIS PRODUCT TO RAIN OR MOISTURE.
DO NOT INSERT ANY METALLIC OBJECT THROUGH VENTILATION GRILLS.

CAUTION:



Explanation of Graphical Symbols



The lightning flash with arrowhead symbol, within an equilateral triangle, is intended to alert the user to the presence of non-insulated dangerous voltage within the product's enclosure that may be of sufficient magnitude to constitute a risk of electric shock to persons.



The exclamation point within an equilateral triangle is intended to alert the user to the presence of important operating and maintenance (servicing) instructions in the literature accompanying the product.

2. Precautions

2.1. Safety

Should any liquid or solid object fall into the cabinet, unplug the unit and have it checked by the qualified personnel before operating it any further. Unplug the unit from the wall outlet if it is not going to be used for several days or more. To disconnect the cord, pull it out by the plug. Never pull the cord itself. Allow adequate air circulation to prevent internal heat built-up. Do not place the unit on surfaces (rugs, blankets, etc.) or near materials (curtains, draperies) that may block the ventilation holes.

2.2. Installation

Do not install the unit in an extremely hot or humid place or in a place subject to excessive dust or mechanical vibration. The unit is not designed to be waterproof. Exposure to rain or water may damage the unit.

2.3. Cleaning

Clean the unit with a slightly damp soft cloth. Use a mild household detergent. Never use strong solvents such as thinner or benzene as they might damage the finish of the unit.

Retain the original carton and packing materials for safe transport of this unit in the future.

Doc # INS-45S17	Issue Date: 02/02/07
Revision: A	Page 3 of 12

3. Federal Communications Commission (FCC) Statement

This Equipment has been tested and found to comply with the limits for a Class B digital device, pursuant to Part 15 of the FCC rules. These limits are designed to provide reasonable protection against harmful interference in a residential installation. This equipment generates, uses and can radiate radio frequency energy and, if not installed and used in accordance with the instructions, may cause harmful interference to radio communications. However, there is no guarantee that interference will not occur in a particular installation. If this equipment does cause harmful interference to radio or television reception, which can be determined by turning the equipment off and on, the user is encouraged to try to correct the interference by one or more of the following measures:

- Reorient or relocate the receiving antenna.
- Increase the separation between the equipment and receiver.
- Connect the equipment into an outlet on a circuit different from that to which the receiver is connected.
- Consult the dealer or an experienced radio/TV technician for help.

You are cautioned that changes or modifications not expressly approved by that party responsible for compliance could void your authority to operate the equipment.

This device complies with Part 15 FCC Rules. Operation is subject to the following two conditions:

- (1) This device may not cause harmful interference.
- (2) This device must accept any interference received including interference that may cause undesired performance.

4. Functional Block Diagram

The following diagram shows the functional block of the 17.0 inches Color TFT / LCD Module:

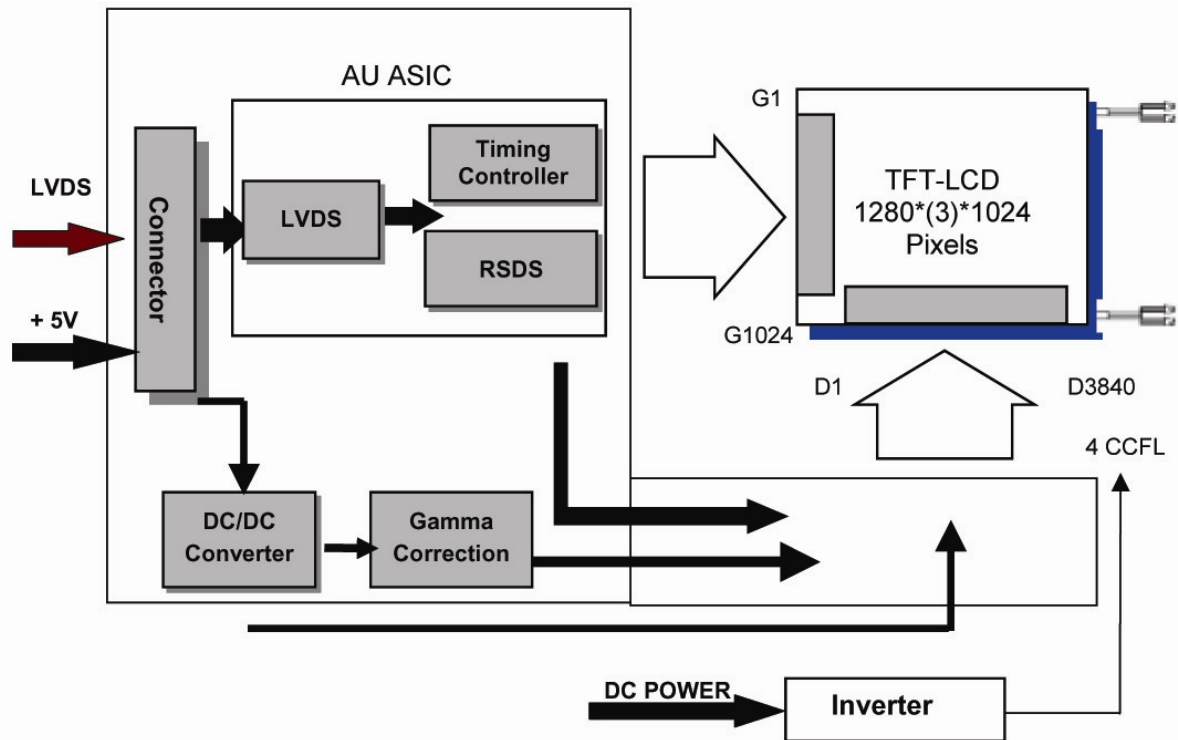

5. Module Connector P in Configuration

The module using a pair of LVDS receivers SN75LVDS82 (Texas Instruments) or compatible. LVDS is a differential signal technology for LCD interface and high speed data transfer device. Transmitter shall be SN75LVDS83 (negative edge sampling) or compatible. The first LVDS port (RxOxxx) transmits odd pixels while the second LVDS port (RxExxx) transmits even pixels.

PIN#	SIGNAL NAME	DESCRIPTION
1	RxOIN0-	Negative LVDS Differential Data Input (Odd Data)
2	RxOIN0+	Positive LVDS Differential Data Input (Odd Data)
3	RxOIN1-	Negative LVDS Differential Data Input (Odd Data)
4	RxOIN1+	Positive LVDS Differential Data Input (Odd Data)
5	RxOIN2-	Negative LVDS Differential Data Input (Odd Data, H-Sync, V-Sync, DSPTMG)
6	RxOIN2+	Positive LVDS Differential Data Input (Odd Data, H-Sync, V-Sync, DSPTMG)
7	VSS	Power Ground
8	RxOCLKIN-	Negative LVDS Differential Clock Input (Odd Data)
9	RxOCLKIN+	Positive LVDS Differential Clock Input (Odd Data)
10	RxOIN3-	Negative LVDS Differential Data Input (Odd Data)
11	RxOIN+	Positive LVDS Differential Data Input (Odd Data)
12	RxEIN0-	Negative LVDS Differential Data Input (Even Data)
13	RxEIN0+	Positive LVDS Differential Data Input (Even Data)
14	VSS	Power Ground
15	RxEIN1-	Negative LVDS Differential Data Input (Even Data)
16	RxEIN1+	Positive LVDS Differential Data Input (Even Data)
17	VSS	Power Ground
18	RxEIN2-	Negative LVDS Differential Data Input (Even Data)
19	RxEIN2+	Positive LVDS Differential Data Input (Even Data)
20	RxECLKIN-	Negative LVDS Differential Clock Input (Even Data)
21	RxECLKIN+	Positive LVDS Differential Clock Input (Even Data)
22	RxEIN3-	Negative LVDS Differential Data Input (Even Data)
23	RxEIN3+	Positive LVDS Differential Data Input (Even Data)
24	VSS	Power Ground
25	VSS	Power Ground
26	NC	No Connection (for AUO test)
27	VSS	Power Ground
28	VCC	+5.0V Power Supply
29	VCC	+5.0V Power Supply
30	VCC	+5.0V Power Supply

6. Inspection Standard

6.1. Inspection environment conditions

Room Temperature: 20~25°

Humidity: 65±5% RH

6.2. The viewing line should be perpendicular to the surface screen.

Dot defect

a) Inspection condition

Inspection distance: 35±5cm

Inspection illumination: 100~150Lux

Panel temperature: 30±5

Inspection pattern: Full white, full black, red, green and blue screens.

b) Acceptable

Item	Area		Total
	A	B	
Blue Black	2	3	4
Red Green White	1	3	3
Total	2	5	7

c) The definitions of A and B zone

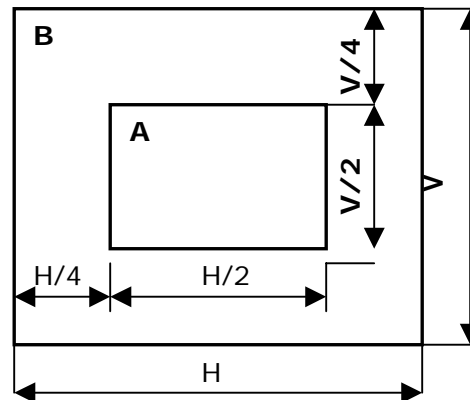

Scratch on the polarizer

Number = 3 max.

Width 0.1 mm, Length 6 mm

Dent on the polarizer

Number = 3 max, Average Diameter \varnothing 0.3 mm

Foreign material on the polarizer

Number = 2 max, Average Diameter \varnothing 0.5 mm

Afterimage

After displaying a pattern for 5 seconds then switch to a different pattern, the previous pattern should disappear within 10 seconds.

Doc # 45M17	Issue Date: 11/09/05
Revision: B	Page 7 of 12

7. Specification

Electrical	45S17
Operating System	NTSC / PAL / XGA / SXGA@60Hz / SVGA
Aspect Ratio	4:3
Picture Diagonal	17.25"
Active Area (W x H)	13.4" x 10.7" (337mm x 270mm)
Resolution (H x V)	1280 x 1024
Response Time	12ms
Video Angle	Up / Down 80 ⁰ , Left / Right 80 ⁰
Brightness	300 cd/m2
Contrast Ratio	500:1
Display Colors	16.2M
Video Input/Output	Video: 1 CH Composite video 1Vp-p 75ohm
In/Out Impedance	75 ohms/ auto termination
Power Source	12V DC
Power Consumption	4.5A / 30W
Environmental	
Ambient Operating Temperature	0° C ~ 50° C (32°F ~ 122°F)
Operating Humidity	20% - 60% R. H.
Mechanical	
Dimensions W x H x D	358mm x 296mm x 17mm (14.1" x 11.6" x 0.67")
Weight	1.9g (0.004 lbs)
Connectors	Video: 1CH BNC input/output
Safety Standards	FCC, CE, UL
Optical	
Lamp Life-time	30,000hr min.
Viewing Angle (Typ.) CR=5	Right, Left, Top, Down = 80 deg
Brightness	300 nit (typ.)
Contrast Ratio	500:1 typical
Response Time	Tr: 6 ms Tf: 2ms (Typ)

8. The Reference of Input Application

8.1. Drive Board w/Input Connectors

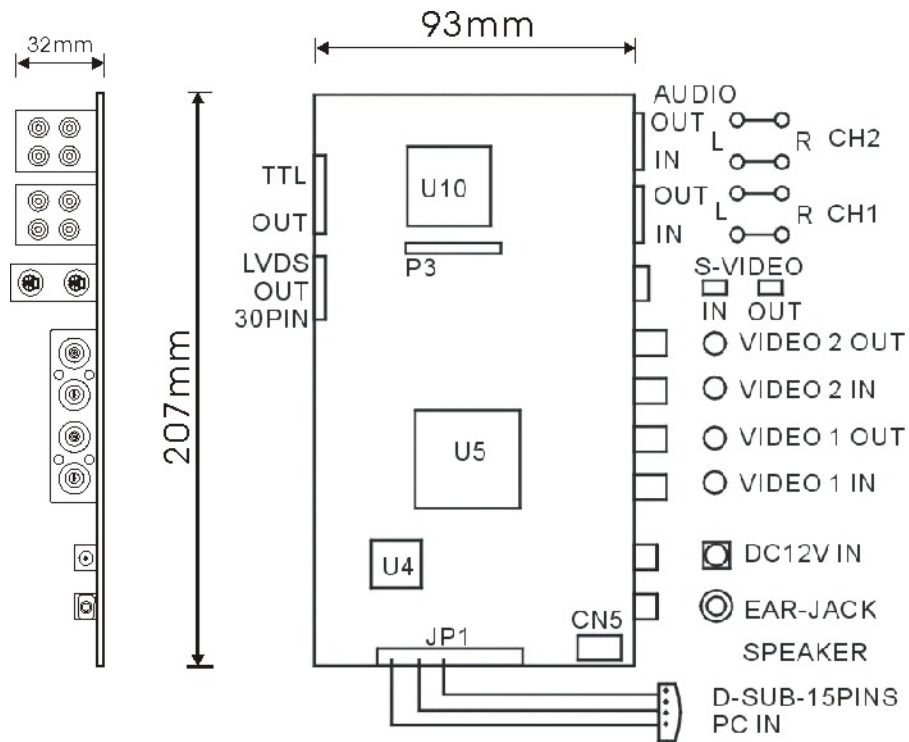

8.2. Function Key Board

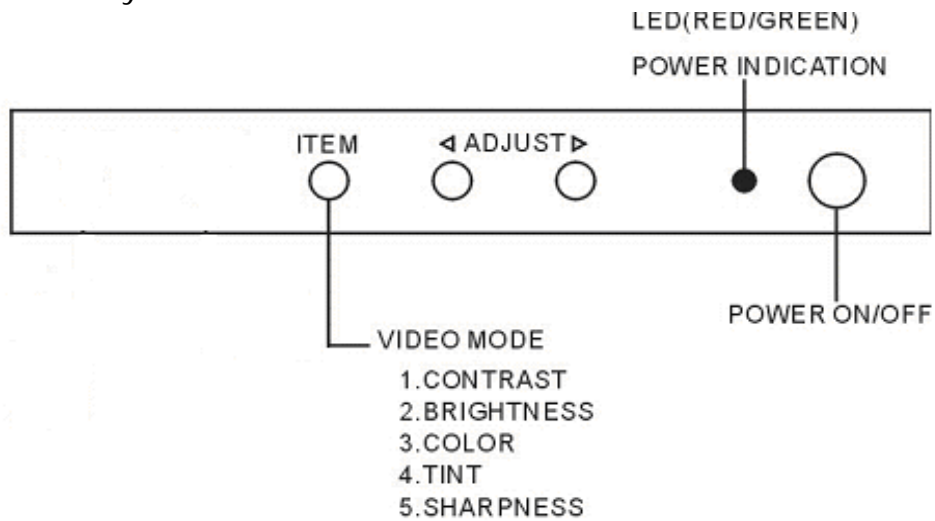

9. Mechanical Characteristics

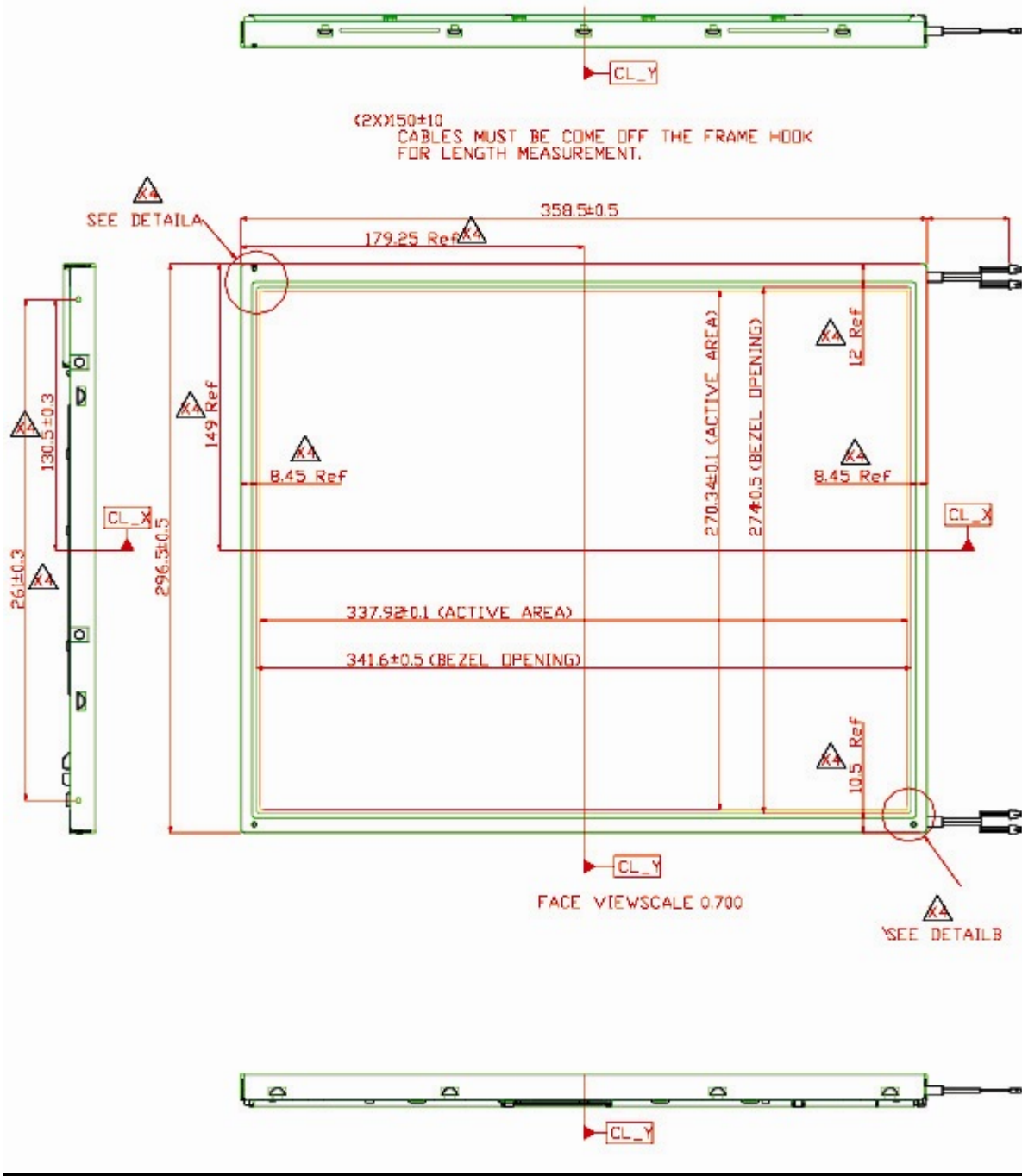

Doc # 45M17	Issue Date: 11/09/05
Revision: B	Page 10 of 12

a-b ≤ 1

c-d ≤ 1

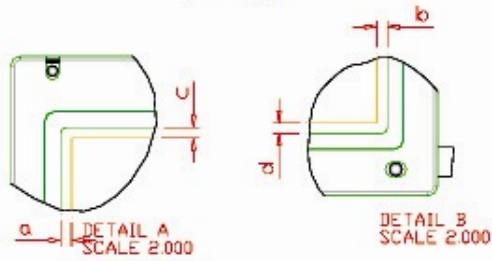

NOTES:

1. BACKLIGHT: 4 *COLD CATHODE FLUDRESCENT LAMPS.
2. I/F CONNECTOR: FI-XB30SRL-HF11.
3. TOLERANCE WITHOUT SPECIFIED TO BE 0.5 MM.
4. LAMP CABLE CONNECTOR TO BE BHSR-02VS-1.
5. THIS DIMENSION EXCLUDES DEFORMATION.
6. TORQUE OF M3 USER HOLE SHOULD BE WITHIN 4 KGF-CM AND RE-SCREW 10 TIMES.
7. FOUR COSMETIC REGIONS SHOWN IN THE REAR SIDE OF THE MODULE ARE PREPARED FOR CUSTOMER BACK MOUNTING DESIGN.

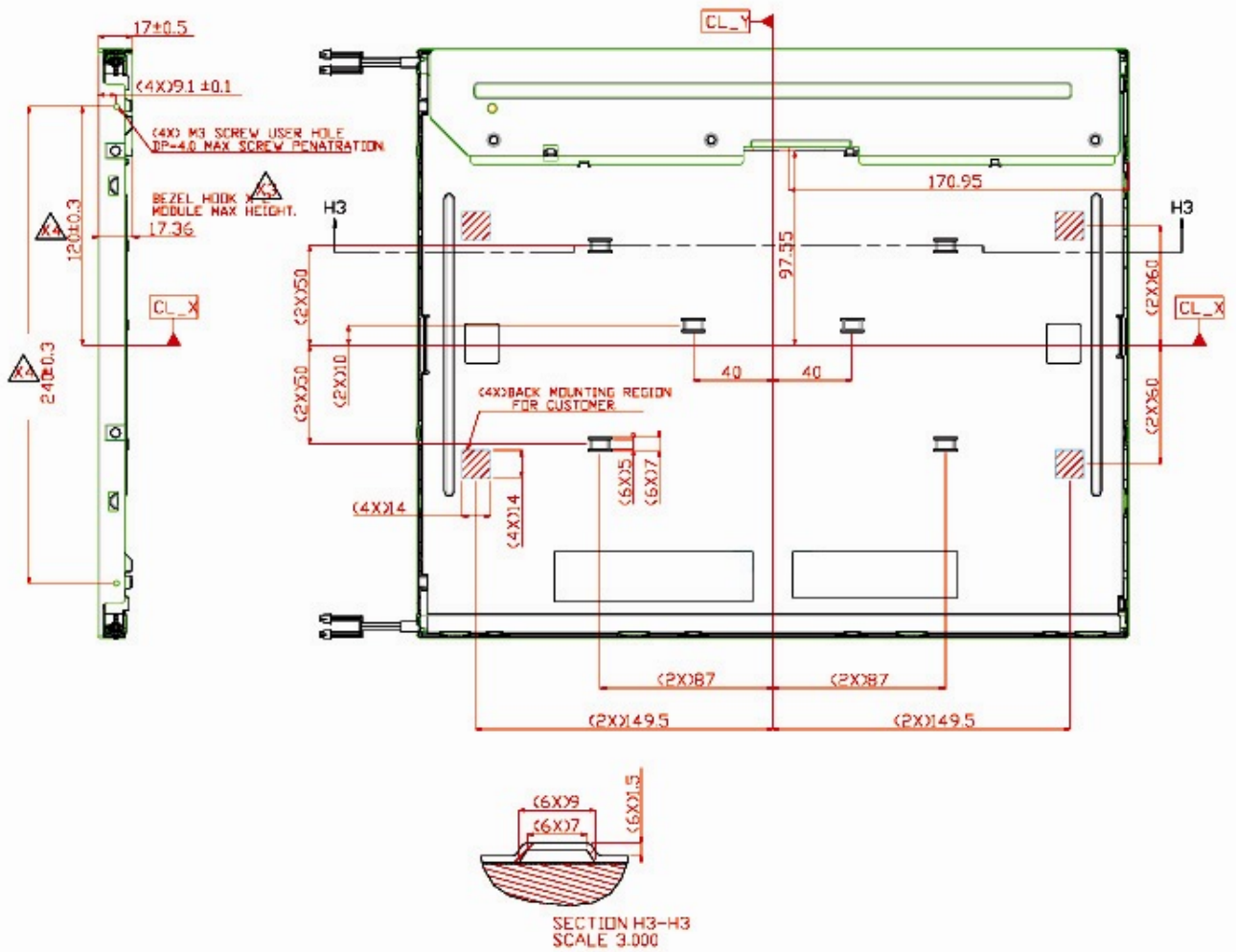

10.Contact

To contact Videology Imaging Solutions:

USA:

Videology Imaging Solutions Inc.
37M Lark Industrial Parkway
Greenville, RI 02828
USA
Tel: (401) 949-5332
Fax: (401) 949-5276

Europe:

Videology Imaging Solutions Europe
Liessentstraat 2-B
NL-5405 AG Uden
The Netherlands
Tel: +31 (0) 413 256 261
Fax: +31 (0) 413 251 712

Please also visit our WEB-site at:

<http://www.videologyinc.com/>

Please note that data in this application note is subject to change without notification!

Videology Imaging Solutions Inc. is an ISO 9001 registered video camera developer and manufacturer serving security, industrial and machine vision, biometric and specialty OEM markets. The main facility is based in Greenville, Rhode Island, USA and Videology Imaging Solutions BV is located in Uden The Netherlands. The company designs, develops, manufactures and distributes video, image acquisition and display products.

Doc # 45S17	Issue Date: 02/02/07
Revision: A	Page 12 of 12