

VIDEOLOGY

IMAGING SOLUTIONS INC.
Original Equipment Manufacturer

Viewer Installation and Operating Instructions Megapixel Color Camera & System 24Z704USB / 24Z704USB-SYS Software SFT-10002 / SFT-10011



24Z704USB



24Z704USB-SYS

Prior to Using This Document: Videology reserves the right to modify the information in this document as necessary and without notice. It is the user's responsibility to be certain they possess the most recent version of this document by going to www.videologyinc.com, searching for the model number, and comparing revision letters on the respective document, located in the document's footer.

For technical assistance with this product, please contact the supplier from whom the product was purchased.

Videology® Imaging Solutions, Inc.



37M Lark Industrial Parkway
Greenville, Rhode Island 02828 USA
Tel: (401) 949 - 5332 Fax: (401) 949 - 5276
North/South American Sales: sales@videologyinc.com
www.videologyinc.com

Videology® Imaging Solutions, Europe B.V.

Neutronenlaan 4
NL-5405NH Uden, The Netherlands
Tel: +31 (0) 413 256261 Fax: +31 (0) 413 251712
European Sales: info@videology.nl
www.videology.nl

Table of Contents

- 1. Document History 3
- 2. General Descriptions..... 3
- 3. Specifications 4
 - 3.1. Mechanical..... 5
 - 3.1.1. 24Z704USB-SYS 5
 - 3.1.2. 24Z704USB..... 5
- 4. Minimum System Requirements 6
- 5. System Setup (24Z704USB-SYS) 7
 - 5.1. Camera Placement..... 7
 - 5.2. Control Panel 7
 - 5.3. Power Connection 7
 - 5.4. Computer Connection..... 7
 - 5.5. Illumination Control 7
 - 5.6. Securing the System to the table top..... 7
- 6. Software (SFT-10002) 8
 - 6.1. Viewer Installation 8
- 7. Basic Camera Controls 10
 - 7.1. Zoom Control..... 11
 - 7.2. Brightness 11
 - 7.3. Exposure Control 11
 - 7.4. Image Orientation Control..... 11
 - 7.5. Image Capture Control (Snapshot) 11
 - 7.6. Advanced Camera Functions..... 12
 - 7.6.1. Manual White Balance..... 12
 - 7.6.2. Focus 13
 - 7.6.3. Shutter Speed 13
 - 7.6.4. User Presets 13
- 8. TWAIN..... 15
 - 8.1. TWAIN Installation..... 15
 - 8.2. TWAIN Interface..... 16
- 9. Contact Information 17

1. Document History

Revision	Issue Date	Details	Author	CN#
Rev A	05-14-10	Initial Release	RJM	10-0089
Rev B	06-07-11	Updated viewer instructions	RJH	11-0074
Rev C	07-05-11	Fixed errors pointing to figure drawings	RJH	11-0085
Rev D	01-16-12	Fixed power consumption (Section 3)	RJH	12-0010

2. General Descriptions

The camera and system are supplied with a software application for camera viewing and control. An SDK is also available for users who wish to integrate the viewing and control features into their own applications.

The 24Z704USB-SYS is an ID badging system utilizing a 2 Megapixel Autofocus USB Zoom camera module and high brightness LED illuminator. It is designed for table top use, and provides high quality streaming video and single frame snapshot capabilities.



- 2 megapixel progressive scan sensor
- WDM, TWAIN, DirectX/DirectShow compatible
- Still image capture with streaming video
- Autofocus, 10x optical zoom
- Cool energy efficient white LEDs replace "hot" incandescent light or flash and last 1000x longer
- On/Off & dimming for LEDs
- No shadows or hotspots due to lighting placement
- Heavy steel construction
- Flexible gooseneck stand
- Small footprint saves table space
- **FIPS 201 compliance (in conjunction with appropriate software)**

The **24Z704USB** camera is a standalone camera; it is not adaptable to the **24Z704USB-SYS** system.



- 2 megapixel progressive scan sensor
- WDM, TWAIN, DirectX/DirectShow compatible
- Still image capture with streaming video
- Autofocus, 10x optical zoom
- **FIPS 201 compliance (in conjunction with appropriate software)**

3. Specifications

Electrical

24Z704USB 24Z704USB-SYS

Image Sensor	1/3" CMOS progressive scan
Active Pixels (HxV)	1280 x 1024
Total Pixels (HxV)	1600 x 1200
Pixel Size	3.0µm x 3.0µm
Scanning System	Progressive Scan
Scanning Frequency (HxV)	19.5KHz x 15Hz
Resolution	800 TVL
Sensitivity	1 lux (30 IRE)
Display Resolution	1280 x 1024
Still Capture	1280 x 1024 pixels
Signal To Noise Ratio	≤ 40dB (max)
Synchronization	Internal
Scan Mode	Progressive scan
Flickerless Mode	Yes (always on, NTSC/PAL configurable)
Contour Enhancement	Yes (text mode or image mode)
Mirror Mode	Yes (horizontal, horizontal + vertical)
Positive/Negative Mode	Yes
Video Output	USB 2.0
Control Communication	USB bus
Shutter Speed	1/20 - 1/1000 sec.
White Balance	Auto/manual
Brightness	Manual
Iris	Auto/manual
Power Supply	12VDC (10 - 14VDC)
Power Consumption	Camera is 1 Amp Max System is 3 Amps
Special Functions	Freeze, H/V reverse, save & recall images
Lighting (24Z704USB-SYS only)	6 lensed super bright LEDs

USB Video

Video Capture	Yes (via software)
High Resolution Still Image Capture	Yes (via software)
Supported Image Formats	Uncompressed YUV422
USB Bandwidth	USB 2.0

Environmental

Operating Temp.	-10°C ~ 50°C (recommended 5° C ~ 40° C)
-----------------	---

Mechanical

Dimensions (WxHxD)	24Z704USB-SYS	13.46cm x 59.69cm x 12.2cm (5.3" x 23.5" x 4.8")
	24Z704USB	66mm x 58.4mm x 114.3mm (2.6" x 2.3" x 4.5")
Weight	24Z704USB-SYS	2.31 kg (5.1 lbs)
	24Z704USB	417g (0.92 lbs)

Software

Viewer (included) SFT-10002	<ul style="list-style-type: none"> • WDM device drivers • DirectX compliant • TWAIN compliant
SDK (optional)	Complete software development kit and support for OEMs
Recommended System Requirements	
Hardware	Pentium IV 2.3GHz +, 1GB hard drive, Intel USB 2.0 Host controller
Software	Windows 7 32 bit, and 64 bit
	Windows Vista 32 bit, and 64 bit
	Windows XP Service pack 2+, DirectX 9.0c or above

Complementary Models

24Z704USB-SYS-P	PAL version (50 Hz) system
24Z704USB-P	PAL version (50 Hz) camera
24Z704USB-KIT	Camera with optional accessories above
24Z704USB-KIT-P	PAL version camera with optional accessories above

Government Compliance

FIPS 201	
<i>In conjunction with appropriate software</i>	

System Includes

24Z704USB-SYS	60C1012	10' USB 2.0 cable
	70V0808	table clamp (x4)
	60PR12DC5.0A-AFZ	12VDC power supply (3A)
	60C0021	USA plug
	SFT-10002	Viewer software
Optional Models		
24Z704USB-SYS-P	60C1118	Euro plug
Camera Kit Includes		
24Z704USB-KIT	70V0423-B	1/4" - 20 mounting block
	60C1012	10' USB 2.0 cable
	60PR12DC5.0A-AFZ	12VDC power supply (3A)
	60C0021	USA plug
	SFT-10002	Viewer software
Optional Models		
24Z704USB-KIT-P	60C1118	Euro plug

3.1. Mechanical

The heavy-duty steel construction of both the stand and camera housing make for a robust and durable design. A flexible gooseneck mount permits the camera to be tilted from back to front or side to side.

3.1.1. 24Z704USB-SYS

The overall dimensions of the system are shown in Figure 1.

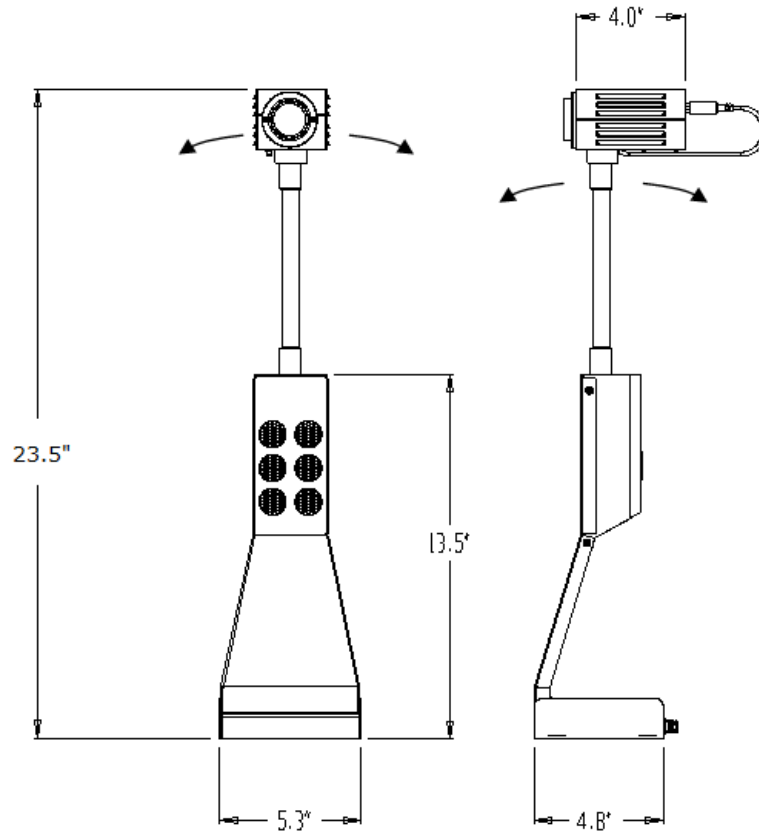

Figure 1. Overall System Dimensions

3.1.2. 24Z704USB

The overall dimensions of the camera are shown in Figure 2.

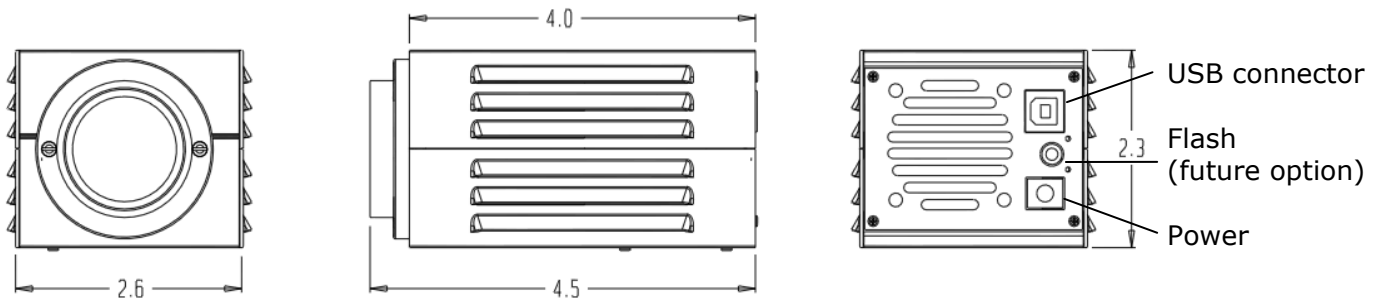

Figure 2. Overall Camera Dimensions

4. Minimum System Requirements

A PC with USB 2.0 compatible port.

USB 1.1 not supported.

MAC is not supported.

Preview only

- PIII- 1.1GHz or above
- 128MB of RAM (256MB preferred)
- Windows XP/2000 for USB2.0
- DirectX/DirectShow 9.0c or later
- Windows XP Service Pack 1 (Service Pack 2 Preferred) Windows 2000 Service Pack 4

Preview and capture at the same time

- Full D1 MPEG 2 - P4 - 2.4GHz or above
- 640 x 480 MPEG 2 - P4 - 2.0GHz or above
- 352 x 288 MPEG1 - P4 - 1.5GHz or above
- Hard Disk - 5400RPM or above (7200RPM preferred)
- 128MB of RAM (256MB preferred)
- Windows XP/2000 for USB2.0
- DirectX/DirectShow 9.0c or later
- Windows XP Service Pack 1 (Service Pack 2 Preferred) Windows 2000 Service Pack 4

Verify system has the latest USB 2.0 host driver from Microsoft® only.

Verify that USB host controller chipset is Microsoft certified.

This product is not guaranteed to operate with a USB 2.0 host driver from OWC.

5. System Setup (24Z704USB-SYS)

5.1. Camera Placement

The system is designed for tabletop use, and should be located within 6ft of the PC to which it will be connected. If necessary, the system may be secured to the table top using the clamps provided (see figure 4)

5.2. Control Panel

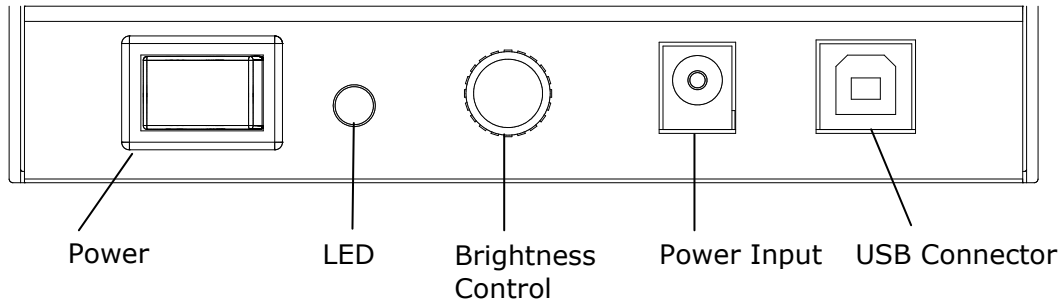

Figure 3. Control Panel

5.3. Power Connection

The power supply is a universal type, and will operate on any 120/240V 50/60Hz AC supply.

Simply plug the AC power cord into a power outlet and connect the output cable from the power supply to the DC input jack on the control panel of the system (see Figure 3)

5.4. Computer Connection

Connect the system to the computer using the standard USB cable supplied.

5.5. Illumination Control

The LED illuminators are housed in the camera stand, and the illumination intensity can be varied using the rotary control located on the base of the unit. See Figure 3.

We recommend that you do not leave the LEDs on full brightness for an extended length of time, as this may reduce their lifetime.

5.6. Securing the System to the table top

The badging system is supplied with small clamps that can be used to secure the system to the tabletop. The clamps are installed into the four rectangular slots in the base and secured to the table with #6 screws as shown in figure 4.



Figure 4. Securing the System to the tabletop

6. Software (SFT-10002)

6.1. Viewer Installation

To install the viewer application on your Windows OS system;

Run the **SetupPZV.exe** program from the CD provided with the system/camera. The Windows Security window opens informing you that the WDM device drivers are not Microsoft® digitally certified.

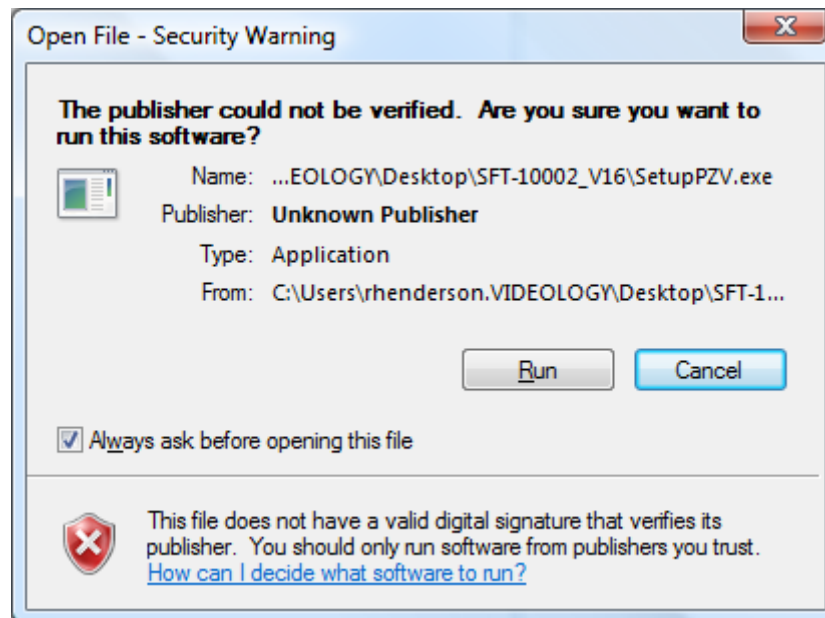

Click **Run**.

The following dialog box will appear.

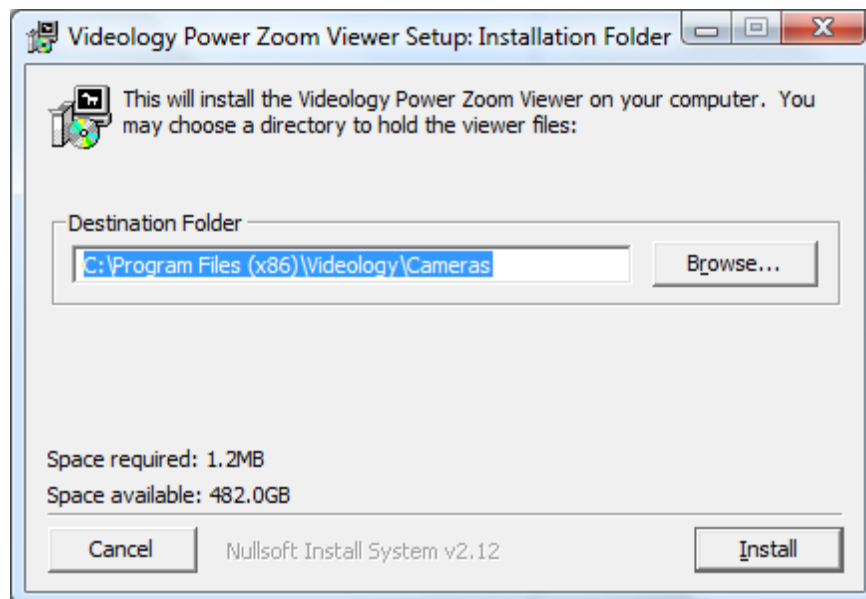

If you wish to install the viewer in a location other than the default directories, click on the **Browse** button and specify the desired location, otherwise click on the **Install** Button, and the following screens will appear

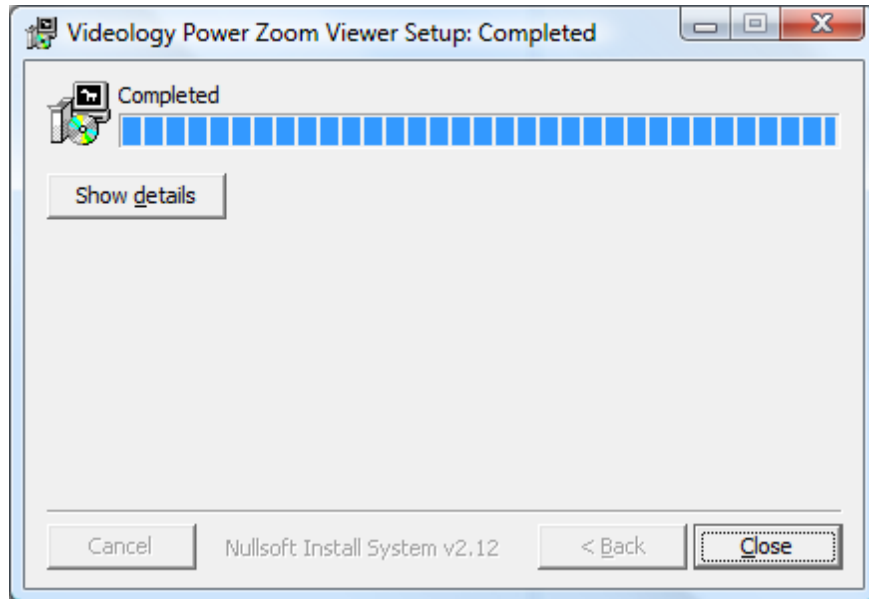

There is no need to install a driver for the camera for normal operation, simply connect the camera to a free USB (2.0) port on your computer and launch the viewer from the desktop icon.



7. Basic Camera Controls

After software installation, open the PowerZoom software

NOTE: Allow a few seconds after connecting the camera to the USB port. The camera is ready for operation when **#1** appears in the box next to the Start button.

Click on the **START** button in the top left hand corner and the camera image will appear.

The viewer includes basic controls for adjusting the Zoom Level, Brightness, Exposure Mode and White Balance Settings of the camera.

Also included within the basic control panel are the Image capture controls:

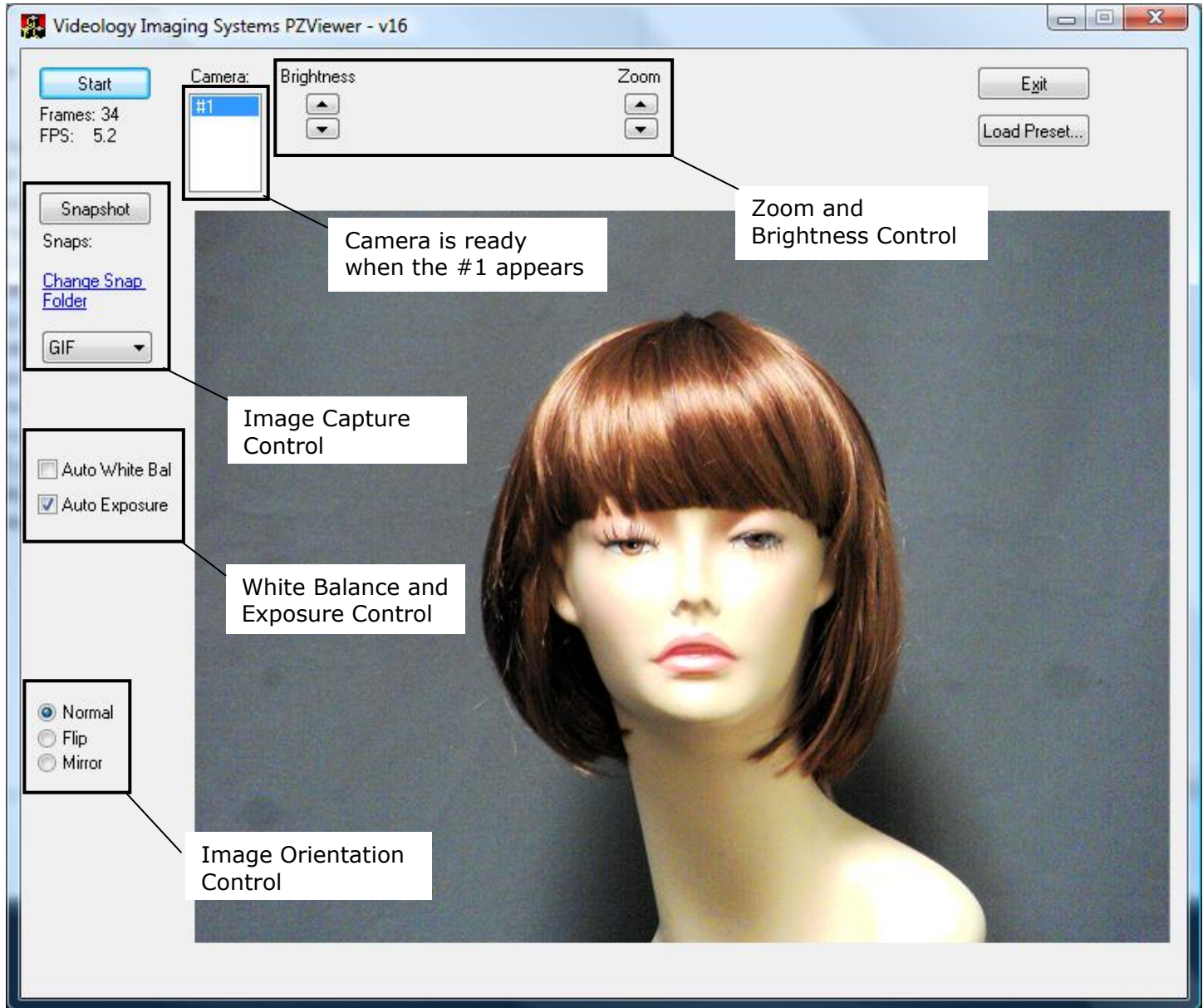

Figure 5. Basic Viewer Control Panel

7.1. Zoom Control

The Zoom control simply adjusts the level of magnification and thus the angular field of view of the camera. To zoom in or out, simply press and hold the up or down arrow (see figure 5) until the required field of view is obtained.

7.2. Brightness

The brightness control adjusts the overall image brightness. To increase or decrease the brightness of the image, simply press and hold the up or down button (see figure 5) until the required image brightness is obtained.

7.3. Exposure Control

If the Auto Exposure control is checked, then the camera will automatically adjust to variations in light intensity by opening or closing the aperture of the lens.

If the Auto Exposure button is unchecked, then the lens aperture will remain at its current setting. It is recommended that the Auto exposure mode be used for most applications, and this is the default setting.

7.4. Image Orientation Control

The image orientation control allows the user to flip the image either horizontally or vertically.

7.5. Image Capture Control (Snapshot)

Single frame images can be acquired and stored to a preset directory. Still image frames can be stored either as Bitmap (BMP), Graphics Interchange Format (GIF), Joint Photographic Experts Group (JPEG), or Portable Network Graphics (PNG) files.

To set the location of the stored images select the "Change Snap Folder" option on the left hand side of the screen. Use the drop-down menu below this to select the required image format.

To acquire an image, simply hit the Snapshot button on the left hand side of the viewer screen.

7.6. Advanced Camera Functions

To access the Advanced Camera Functions, press **"Ctrl D"** on the keyboard. The following screen options will appear:

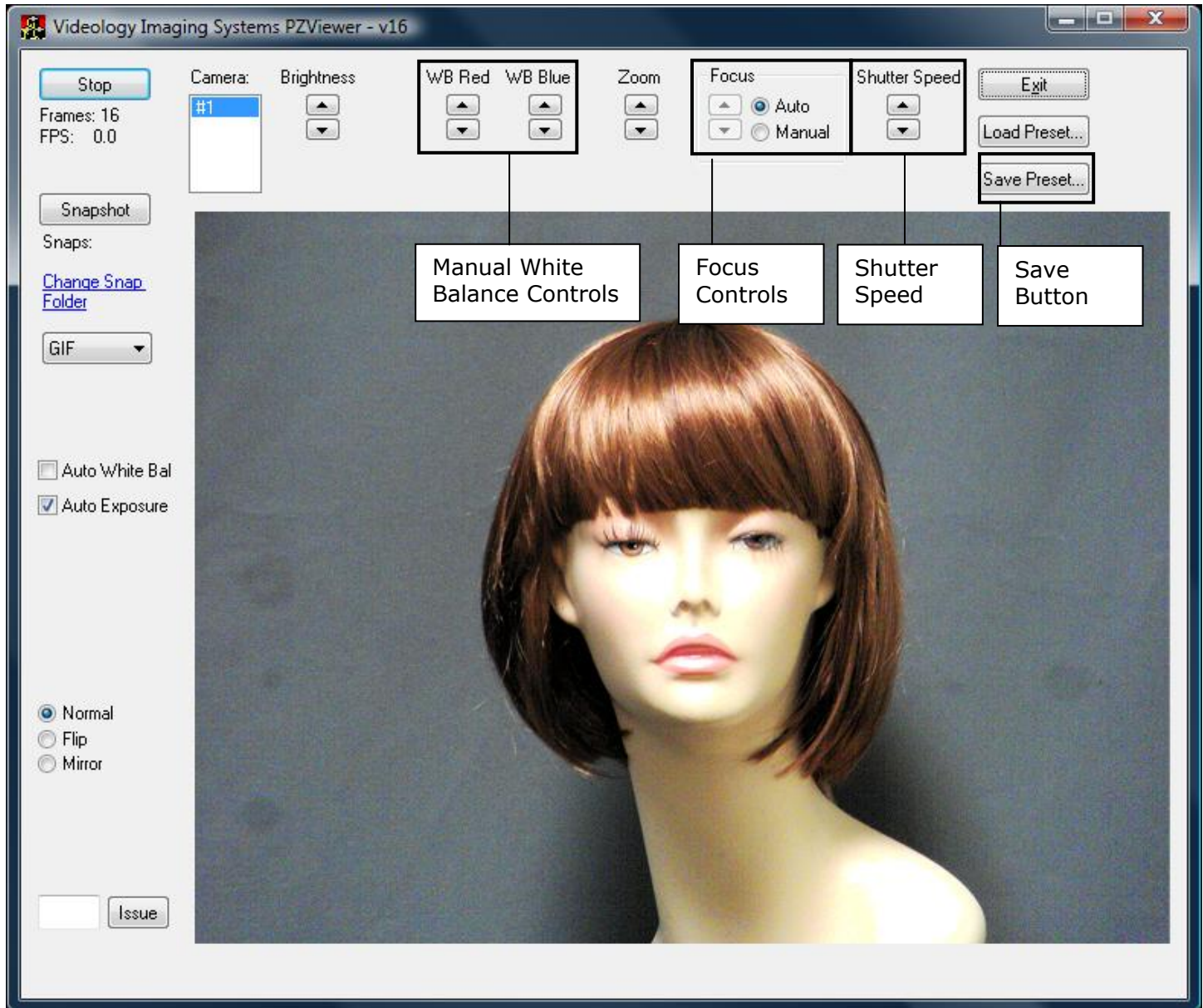

Figure 6. Advanced Image Controls

The advanced function menu allows you to adjust the following parameters:

7.6.1. Manual White Balance

The manual white balance controls allow you to change the way in which colors are displayed.

When using different types of lighting (fluorescent lights, incandescent lamps, sunlight etc.) color tones can vary, and to get the best color representation, it may be better to override the auto white balance feature of the camera and adjust the red and blue gain channels to achieve optimum color balance of the subject.

For example, the color of objects viewed under incandescent lighting are shifted towards the red, whereas Fluorescent lighting can make objects appear bluer.

There are two modes of operation of the White Balance control, automatic (AWB) and manual.

In automatic mode the camera will adjust the colors automatically as the lighting conditions change. In manual white balance, the user can adjust the color settings to obtain the best color reproduction.

NOTE: The manual color controls are only accessible via the Advanced Camera Functions.

7.6.2. Focus

The 24Z704USB Badging camera is capable of focusing in both Automatic Mode and Manual Mode. It is important to note that the camera defaults to the setting previously set in either Videology Viewer Mode or Badging Software Mode.

Because of this, it is important to always set the radio button for the Focus Control to your preference (Auto Mode/Manual Mode) when using the camera for the first time. (See Figure 6)

7.6.2.1. When Autofocus Fails

Occasionally the camera may have difficulty focusing especially in marginal lighting environments.

Low contrast subjects, blue backgrounds or solid color walls, highly reflective subjects, or subjects in front of a very detailed background, may require adjustments to focus.

In these situations it is best to set the camera from Auto Mode to Manual Mode and adjust the focus.

Alternatively, the user can zoom out a bit in Auto Mode, which will cause the camera to refocus.

7.6.3. Shutter Speed

The shutter speed sets the integration time of the camera; this is analogous to the speed of a mechanical shutter on a conventional camera.

To increase or decrease the shutter speed, simply press the up or down arrow. Each time you press the arrow, the shutter speed will be incremented by one step.

A slow shutter speed should be used in low light conditions; a faster shutter speed should be used if the subject is moving quickly or under excessive light conditions.

7.6.4. User Presets

When first setting up the 24Z704USB camera you may wish to establish Presets. The badging camera has 8 presets available that allow focus, white balance, etc. to be set for easy retrieval in subsequent camera usage.

It is recommended that before saving a preset, the Manual radio button be set so that the camera "locks" in the desired Field of View immediately when a preset is retrieved.

To save the current camera settings, simply click on the "Save Preset" button, and select one of the presets 1 through 8.

NOTE the save function is only available through the advanced control panel (see figure 6), although the preset can be recalled (loaded) via the basic control panel.

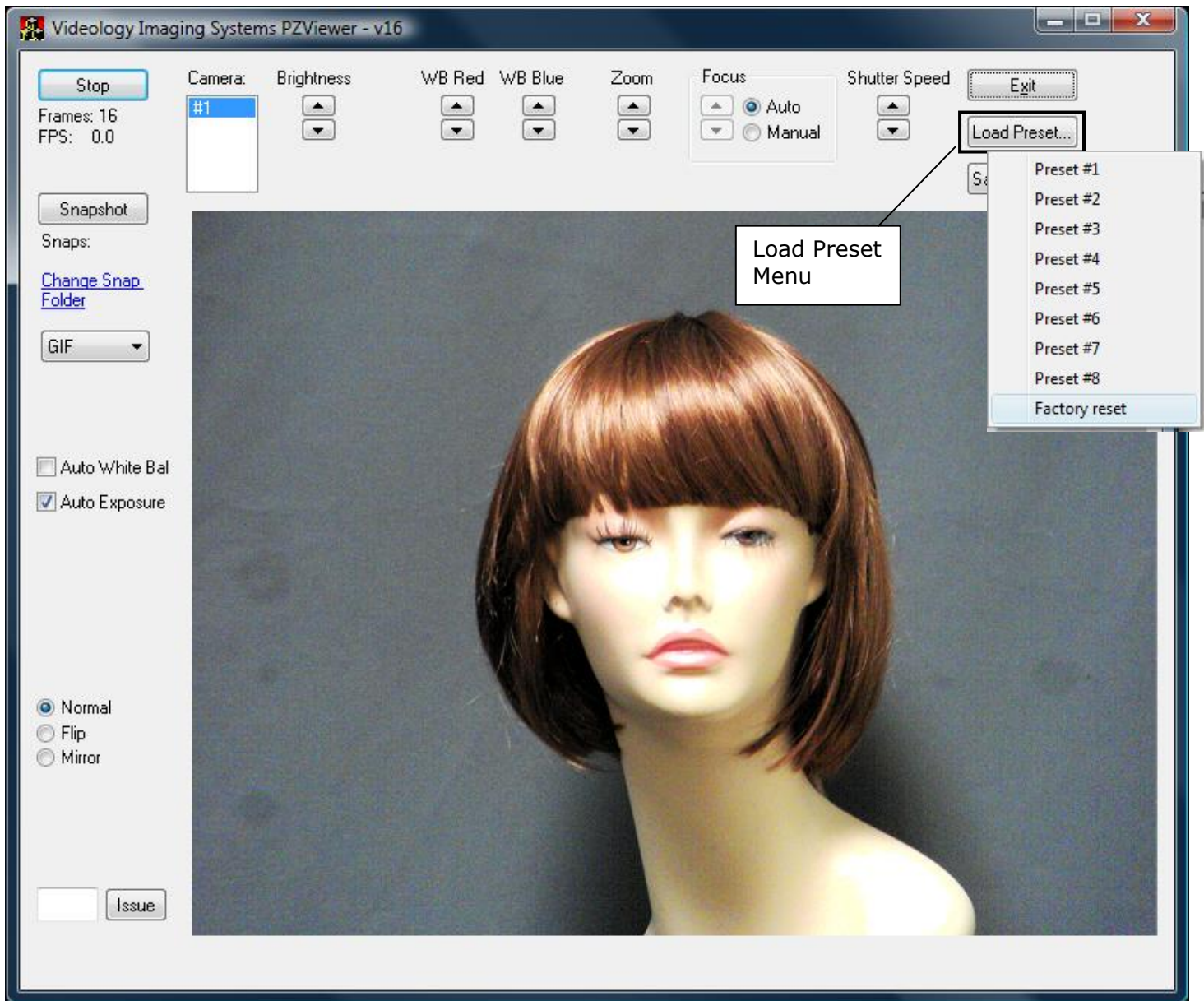

Figure 7. User Preset Options

To restore the camera to the factory default settings, select the Factory Reset option from the drop down list on the load presets menu.

8. TWAIN

8.1. TWAIN Installation

To install the TWAIN data source, insert the CD labeled **Twain Data Source** and double click the executable file named **SFT-10011 - TDS**.

Note: the file name might be slightly different depending on the revision level of the software.

The following window will appear.

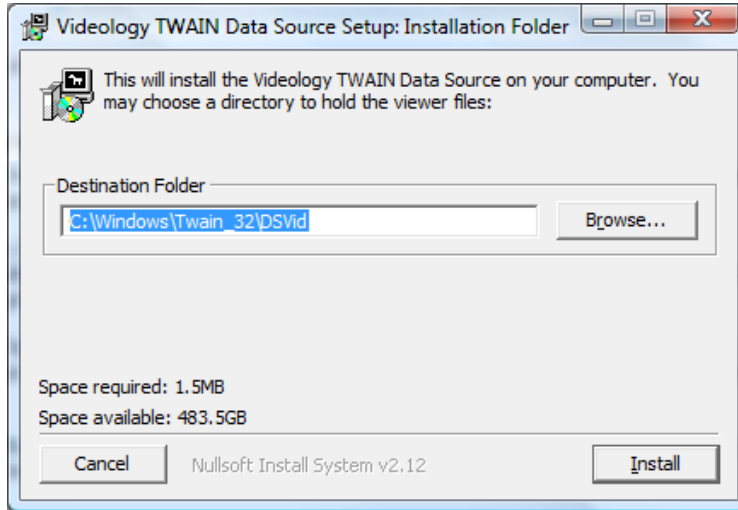

Do not install the TWAIN data source in any other folder other than the default folder. To do so will make the camera system inoperable.

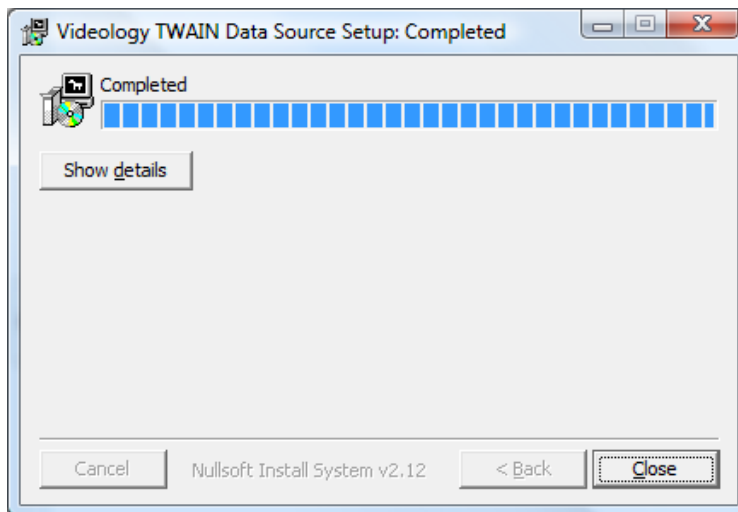

The TWAIN driver installation is now complete. Click **Close** to exit the hardware wizard.

8.2. TWAIN Interface

If you have installed the Twain interface (**SFT-10011 - TDS**), you can use the camera with any TWAIN Compliant Application.

The TWAIN interface will attach itself to the first Videology camera it finds connected to the computer. For the best operation, the Twain Interface is intended to run on a system with only one Videology camera installed.

Any application that supports a TWAIN Data Source as a capture device can access the camera. The camera's image will appear as shown below.

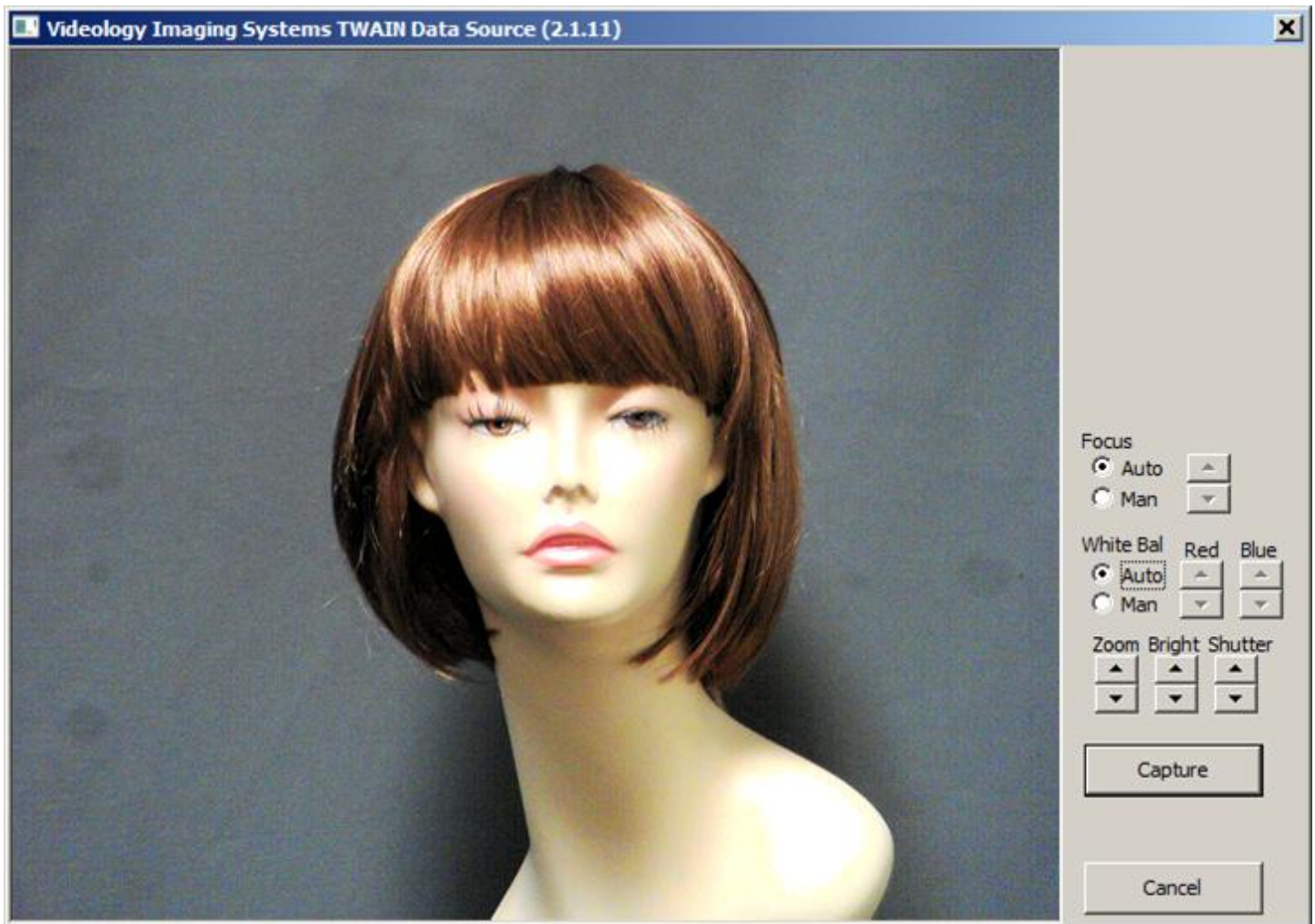

For descriptions of camera options, please refer to section 6.

9. Contact Information

For technical assistance with this product, please contact the supplier from whom the product was purchased.

For OEM inquiries, contact Videology Imaging Solutions:

North / South America:	Europe:
Videology Imaging Solutions Inc. 37M Lark Industrial Parkway Greenville, RI 02828 USA Tel: (401) 949-5332 Fax: (401) 949-5276	Videology Imaging Solutions Europe Neutronenlaan 4 NL-5405 NH Uden, Netherlands Tel: +31 (0) 413 256 261 Fax: +31 (0) 413 251 712

Please visit our WEB-site at: <http://www.videologyinc.com/>

VIDEOLOGY IMAGING SOLUTIONS is an ISO 9001 registered video camera developer and manufacturer serving industrial, machine vision, biometric, security, and specialty OEM markets. Videology designs, develops, manufactures, and distributes video, image acquisition, and display technologies and products to OEMs worldwide.