

# VIDEOLOGY®

## IMAGING SOLUTIONS INC.



### Operation Manual

#### 20D779 / 21D779

### BOX CONTENTS

1. 20D779 NTSC or 21D779 PAL Color Camera
2. Operation manual

### SAFEGUARDS & WARNINGS

1. Read instructions before operating camera.
2. Avoid mounting in direct sunlight.
3. Installation and repair should be undertaken by authorized personnel only.

### SOFTWARE CONTROL

Please refer to 20D479/21D479 application notes for software commands.

### SPECIFICATIONS

Electrical	20D779 (NTSC)	21D779 (PAL)
CCD Sensor	1/3" IL Color CCD	
Active pixels (HxV)	768 x 492	752 x 585
Horizontal Resolution	450 TVL CVBS 490 TVL YC	
Sensitivity	0.5 lux	
Signal to noise ratio	> 46dB	
Gamma	0.45 default or 1 selectable via dip switch or I <sup>2</sup> C bus	
Gain	Automatic (26 dB default) Manual / Fixed via software	
Synchronization	Internal or H&V lock, Default on HD/VD Sync out	
Back light compensation	Selectable via software	
White balance	Automatic (default) 3 Fixed modes via software Push to set via hardware or software	
Shutter speed	8 Fixed speeds via hardware 11 Speeds via software	
	Automatic from 1/60 to 1/20,000	Automatic from 1/50 to 1/20,000
Contour enhancement	Selectable Horizontal and Vertical via software/ dip switch	
Mirror mode	On/Off Selectable via software/ dip switch	
Iris signal	Electronic	
Iris controls	Electronic (default), fixed shutter speeds (8 values)	
Video output	Analog Composite 1Vp-p video (75 Ohms) Y/C (S-Video)	
Power Supply	8-16VDC (12VDC optimal)	
Power Consumption	< 2.4W	
<b>Environmental</b>		
Operating Temp.	-15° ~ 55° C	
Storage Temp.	-25° ~ 60° C	
<b>Mechanical</b>		
Dimensions (WxHxD)	50mm x 60mm x 62.5mm	
Lens Mount	CS mount	
<b>Accessories</b>		
Optional	60PR12DC800	12VDC regulated power supply
	60VZZ0030C	Mount with adapter ring
	Mounting plate - top or bottom mountable	
	DC in/ control communication kit available on request	

### CONNECTORS

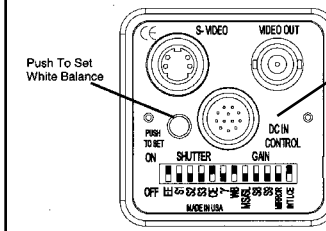

CN3 12 Pin Connector

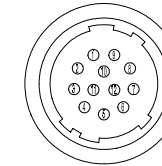

#### DC IN / Control

Pin	Function
1	GND
2	+12V DC
3	GND
4	CVBS Out
5	GND
6	Hsync in / HD Out*
7	Vsync in / VD Out*
8	GND
9	
10	12C Data
11	12C Clock
12	GND

Synchronization mode set by dip switch 8. See below.

### CONTROLS

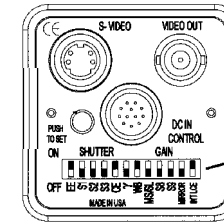

#### DIP SWITCHES

Pos'n	Function
1	Electronic Iris On / Off
2	S1 - Fixed Shutter Speed
3	S2 - Fixed Shutter Speed
4	S3 - Fixed Shutter Speed
5	Contour Enhancement On/Off
6	Gamma 0.45 / 1
7	AWB / Push
8	S8 - Synchronization Mode
9	S9 - Gain Control
10	Gain Control
11	Mirror Mode On / Off
12	Interlace On / Off

### DIMENSIONS

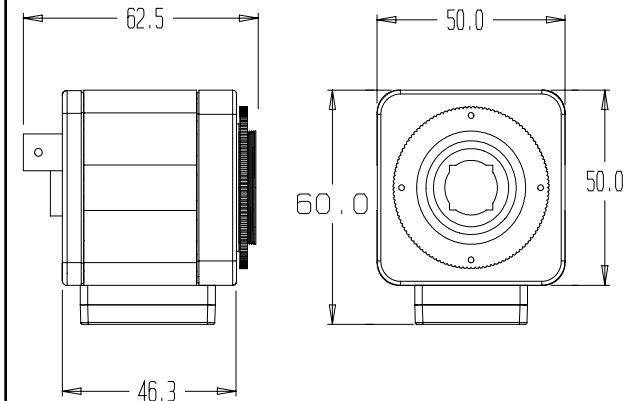

## OPERATING INSTRUCTIONS

### 1.1 Iris Control (Shutter Speed)

The Iris setting is used to control the image intensity in varying lighting conditions. It works by varying the integration time of the camera, which is measured in fractions of a second, and is analogous to the shutter speed on a conventional camera. The shutter speed is set by Dip Switches 1-4, according to Table 1.

TABLE 1

Shutter Speed		Dip Switch			
20D779	21D779	1	2	3	4
1/60 sec. (max)	1/50sec. (max)	Off	On	On	On
1/100 sec. (Flickerless)	1/120 sec. (Flickerless)	Off	On	On	Off
1/250		Off	On	Off	On
1/500		Off	On	Off	Off
1/1000		Off	Off	On	On
1/2000		Off	Off	On	Off
1/10000		Off	Off	Off	On
1/20000		Off	Off	Off	Off
Electronic Iris		On	x	x	x

The flickerless mode is intended for use in environments illuminated by fluorescent lamps. These lights can cause excessive flickering of the image if the shutter speed is not set appropriately.

In the Electronic Iris mode, the integration time of the camera is automatically adjusted according to the level of illumination.

### 1.2 Contour Enhancement

The contour enhancement is used to increase the sharpness of the image, by slightly exaggerating the boundaries between light and dark areas of the screen. It may give rise to image artifacts depending upon the scene content, and the appropriate setting is best established by experimentation.

*The contour enhancement is enabled via Dip Switch #5 (On).*

### 1.3 Gamma

The gamma control defines the overall transfer function of the camera. That is the relationship between the incident light intensity and the amplitude of the video output signal. A gamma of 1 defines a linear relationship, and is best suited for use with image capture devices. A gamma setting of 0.45 is used to offset the non-linear response of the phosphors used in video monitors, and this should be used when viewing the camera on such a monitor.

The gamma is selected Via software control or Dip Switch #5 (ON = .45, OFF =1)

### 1.4 Synchronization

There are synchronization modes, selectable via Dip Switches 7 and 8.

In mode 1, the camera timing will be derived from the internal crystal or lock to externally supplied H and V pulses (Master Mode).

In mode 2, the camera timing will sync. to external H and V pulses. See Application note "APN-20D479", section 4.3 for more information on external synchronization.

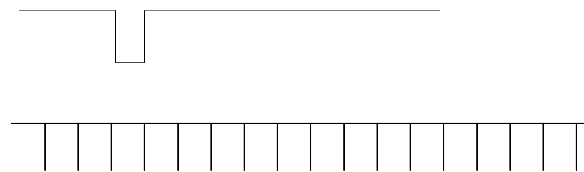

Sync Mode	Dip Switch
Mode 1. Master (Internal Sync.)	8 Off
Mode 2. Slave	On

### 1.5 White Balance

The camera has 2 white balance modes. AWB (auto white balance) allows the camera to adjust white balance based on the scene.

Push to set (PUSH) sets the white balance to fixed values determined at the time the button is pushed.

White Balance Mode	Dip Switch
	7
Mode 1. AWB	On
Mode 2. PUSH	Off

### 1.6 Gain Control

The camera can be set to Automatic Gain Control (Dip Switches 9 and 10 Off) whereby the gain of the camera will be varied in response to changes in the average level of illumination.

Alternatively, the gain can be set to one of three fixed values as defined in the table below.

Gain Setting	Dip Switch	
	9	10
AGC On	On	On
0 dB	On	Off
6 dB	Off	On
12 dB	Off	Off

### 1.7 Mirror Mode

This option is used to perform a mirror inversion of the camera image, and is used when the camera is viewing the object via an external mirror. The mirror mode is enabled by setting Dip Switch #11 to the ON position.

### 1.8 Non Interlace Mode

In the normal mode, the camera outputs thirty full frames per second. Each frame is comprised of two interlaced fields, each containing 262 lines. The presence of the interlace can cause problems when capturing images of moving objects, due to the temporal separation of the fields. In the non interlaced mode, the camera outputs two identical fields per frame. In the non interlaced mode, the vertical resolution of the image is reduced by a factor of 2.