

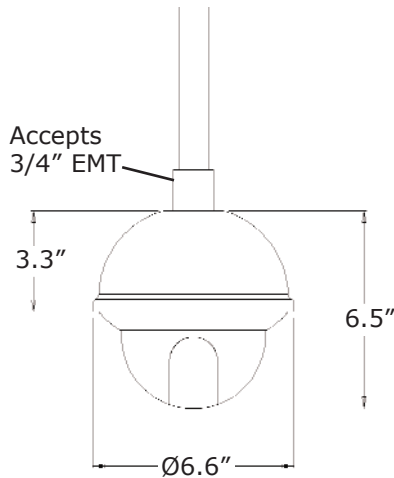

For Ceiling Mount Applications Via Standard 3/4" Conduit  
All Metal Ruggedized Cost Effective 5" Dome Pendant Mounts

- All Videology 5" Domes Swivel In To LOCK In Place - FAST & EASY
- Contemporary Design
- Ruggedized Models



### Specifications

	77PND5B Black	77PND5C Cream
Construction	Aluminum and Steel	
Dimensions (Ø x H)	6.6 x 3.3"	
Weight	1.5 lbs	

### Ruggedized Impact Resistant Pendant Camera

D5PF9 & DB5PF9 Series of 5" domes incorporate a highly resistant, polycarbonate bubble. In conjunction with above pendant mount a highly ruggedized single unit is created, unbreakable with standard forces. Direct blows to the unit lock- tightens the unit.