



Monitor Features

- NTSC/PAL Auto Selectable
- Looping or Auto Termination (75 Ohms)
- PC Input
- VESA Standard Bracket
- Remote Control

Camera Features

Optional Cameras :

- **Wide Dynamic Range Camera**
 - 1/3" CMOS Digital Pixel System
 - 102dB Dynamic Range
- **540 TVL Camera**
 - 1/3" IL CCD
 - 0.2 LUX

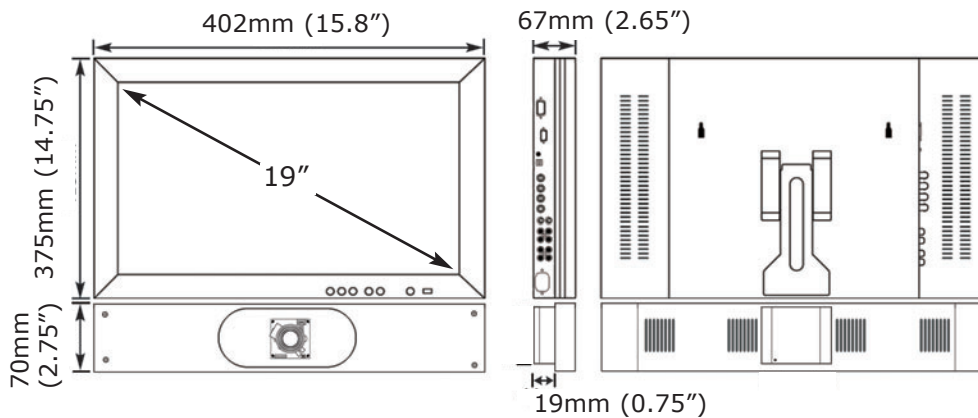

Technical Specifications

<i>Electrical (Camera)</i>	45M19-W	45M19-B
Image Sensor	1/3" CMOS – Digital Pixel System®, (WDR)	1/3" IL CCD
Sensitivity	0.6 Lux (30 IRE) f1.2	0.2 Lux (30 IRE) f1.2
Resolution	480TVL	540TVL
Total Pixels (H X V)	742 x 552	NTSC (768 X 492) PAL (752 x 582)
Synchronization	Internal/External	Internal
Signal to Noise Ratio	>48dB	>48dB
Gain Control	AGC	AGC
Dynamic Range	102dB Typical	50dB
Lens	6mm Fixed	6mm Fixed

<i>Electrical (monitor)</i>	
LCD Panel	19" Digital TFT screen
Resolution	1280 x 1024
Active Area	576mm x 324mm
Aspect Ratio	4:3
Display Colors	16.2M
Brightness	300 cd/m ²
Contrast Ratio	800:1
Viewing Angle	Up 80°, Down 80°, Left 80°, Right 80°
Response Time	5ms
Input/Output Signal	Composite video, 1Vp-p @75ohm
Power Source	12VDC
Power Consumption	<50W / 3.33A

Mechanical

Dimensions (W x H x D)	402mm x 375mm x 70mm (15.8" x 14.75" x 2.75")
Weight	5.9 kg (13 lbs)
Accessories <i>Included</i>	Power supply Power cord Bracket: VESA 100 standard
Connectors	BNC 1 In/1 Out RGB 1 In

Environmental

Operating Temperature	-10°C ~ 60°C (14°F ~ 140°F)
Operating Humidity	20% - 80%

Optional Models

45M26-WP	PAL version with 1/3" CMOS – Digital Pixel System®, (WDR)
45M26-BP	PAL version with 1/3" IL CCD

Safety Standards

	FCC, CE, UL, RoHS, Energy Star
--	--------------------------------

04/27/09 PDS-45M19-X REV A

All data subject to change without notice.

Videology® Imaging Solutions, Inc.



37M Lark Industrial Parkway
Greenville, Rhode Island 02828 USA
Tel: (401) 949 - 5332 Fax: (401) 949 - 5276
North/South American Sales: Sales@videologyinc.com

Videology® Imaging Solutions, Europe B.V.

Neutronenlaan 4
NL-5405NH Uden, The Netherlands
Tel: +31 (0) 413 256261 Fax: +31 (0) 413 251712
European Sales: Info@videology.nl