

VIDEOLOGY®

IMAGING SOLUTIONS INC.
Original Equipment Manufacturer

High Resolution USB 2.0 B&W Board Camera

20K13XUSB-C/21K13XUSB-C

Product Features

- All-digital design uses camera board's digital (D1) output for input to USB board
- CCD sensor provides near IR sensitivity to 0.005 lux
- USB 2.0 bus provides power to camera
- Complete SDK available

Software

- USB 2.0 viewer software and Microsoft Digitally Certified WDM Device Drivers for 32bit and 64bit Windows operating systems
- DirectX/DirectShow compliant
- TWAIN compliant
- **Linux driver available**

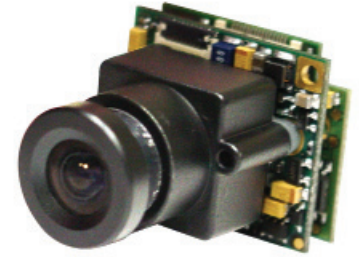

20K135USB-C shown
(w/M-12 mount & optional lens)

Technical Specifications

Electrical	20K13XUSB-C	21K13XUSB-C
	EIA	CCIR
Image Sensor	1/4" Sony Ex-View® CCD	
Active Pixels (HxV)	768 x 494	752 x 582
Viewer Display	720 x 480 pixels max (USB 2.0, 30fps)	720 x 576 pixels max (USB 2.0, 30fps)
Sensitivity	<0.005 Lux, near IR sensitive	
Signal to Noise Ratio	> 48 dB (AGC off)	
Gamma	0.45 default (1.0 via Software)	
Gain Control	Automatic 36 dB (AGC default) or Fixed options via software	
Scan Mode	Interlaced / Non Interlaced (selectable via software)	
Mirror Mode	Selectable via software	
Synchronization	Internal	
Back Light Compensation	Default on (selectable via software)	
Contour Enhancement	Default on	
Iris Control	CCD Iris default	
Shutter Speeds	Automatic	
	14 fixed speeds via software 1/7.5 to 1/100,000	14 fixed speeds via software 1/6.5 to 1/100,000
Control Communication	Camera control via USB bus	
Power Supply	5VDC via USB bus	
Power Consumption	< 1.3 W	

Mechanical

Dimensions W x H x D	26mm x 22mm x 16mm (1.02" x 0.86" x 0.62") (without lens mount)		
Weight (w/ M-12 mount)	19g (0.67oz)		
Lens Mounts	Replace "X" in model number with desired lens:		
Example: Change 20K13XUSB-C to 20K135USB-C to select an M-12 board mount.	2 = Metal M-12 Pinhole	5 = Metal M-12 Board	8 = Metal CS Board
Connectors	Camera to USB board: Board to board connector USB board connector: (6 pin) power & data		

Standards

	RoHS
--	------

Pinouts and Dimensions

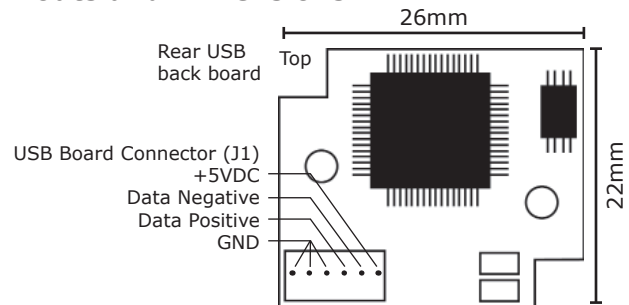

Environmental

Operating Temperature	-15° C ~ 55° C (5° F ~ 131° F)
Storage Temperature	-25° C ~ 70° C (-13° F ~ 158° F)
Operating Humidity	20 up to 93%RH
Storage Humidity	Up to 98%RH
Lifetime	MTBF > 150000
Packaging	ESD safe package

Note: Camera is not USB 1.1 compliant

Software

Viewer (included) SFT-07019	<ul style="list-style-type: none"> • WDM device drivers • DirectX/DirectShow compliant • TWAIN compliant (requires driver installation)
SDK (optional) SFT-07019-SDK	Complete software development kit and support for OEMs

Recommended System Requirements

Hardware	Pentium IV	2.3GHz +, 1GB hard drive, Intel USB 2.0 Host controller
Software	Windows 7	32 bit and 64 bit
	Windows Vista	32 bit and 64 bit
	Windows XP	Service pack 2 +, DirectX 9.0c or above

Accessories

Optional USB 2.0 cable	60C1062	8 ft. (2.4384m)
	60C1062-1	40 in. (1.016m)
	60C1062-2	12 in. (304.8mm)
	60C1062-3	6 in. (152.4mm)
	60C1062-4	15 ft. (4.572m)

Complementary Models

20K15XUSB-C	High resolution color USB 2.0 board camera
20K14XUSB-C	Standard resolution color USB 2.0 board camera
20K14XUSB-CDN	USB 2.0 Day/night color board camera <i>Note: Day/night optical filter (or no filter) options for maximum sensitivity in B&W mode</i>

09/13/11 PDS-20K13XUSB-C Rev C

All data subject to change without notice.

Videology® Imaging Solutions, Inc.

37M Lark Industrial Parkway
Greenville, Rhode Island 02828 USA
Tel: (401) 949 - 5332 Fax: (401) 949 - 5276
North/South American Sales: sales@videologyinc.com
SGS www.videologyinc.com

Videology® Imaging Solutions, Europe B.V.

Neutronenlaan 4
NL-5405NH Uden, The Netherlands
Tel: +31 (0) 413 256261 Fax: +31 (0) 413 251712
European Sales: info@videology.nl
www.videology.nl